

Garlock Butterfly Valves Technical Catalog



TABLE OF CONTENTS

GARLOCK BUTTERFLY VALVES

Overview.....	3
The correct type of lining.....	4
Head flange, body, flange type, design and shaft sealing.....	5
Materials.....	6
Production.....	7
Test engineering.....	8
Standards.....	9
The correct material choice for your application.....	10

GAR-SEAL, SAFETY-SEAL AND MOBILE-SEAL

Applications GAR-SEAL.....	11
Applications SAFETY-SEAL.....	12
Applications MOBILE-SEAL.....	13
Materials.....	14
Dimensions, Wafer.....	15
Dimensions, Lug.....	16
Exploded view.....	17

STERILE-SEAL

Applications.....	18
Bacteria won't survive.....	19
2-chamber-system guarantees product safety.....	20
Materials.....	21
Dimensions, Wafer.....	22
Dimensions, Lug.....	23
Exploded view.....	24

ANCILLARY COMPONENTS

Mounting flange.....	25
Hand-Lever.....	26
Gear Operator.....	27

TECHNICAL DETAILS

Technical data.....	28
Special vacuum design.....	30

Garlock Butterfly Valves

Trusted throughout chemical, petrochemical and many other industries

FOR CORROSIVE AND ABRASIVE MEDIA

Butterfly Valves

Garlock Butterfly Valves are renowned throughout the chemical, petrochemical, process and many other industrial sectors for their quality, performance and reliability in arduous conditions. Garlock valves set the standard in TA-Luft compliance, plus the valves are certified with S1L 3 according to EN 61508.

GAR-SEAL

GAR-SEAL valves are used extensively where corrosive, abrasive and toxic media need to be reliably controlled. They are typically used for accurate control, throttling and shut-off duties in the chemical, petrochemical, chlorine, paper, electro-plating and many other industries. GAR-SEAL butterfly valves offer reduced maintenance requirements and increased operational reliability.



GAR-SEAL

STERILE-SEAL

STERILE-SEAL valves are used in applications where sterile processes need to be maintained in the pharmaceutical and food industries without unnecessary and costly overhauls and replacement. The special characteristic of this valve is its external sterilization capability. The design is such that the critical „dead“ areas of the valve, as well as the disc, body liner and seals, can be sterilized with steam without coming in contact with the process medium.



STERILE-SEAL

SAFETY-SEAL

SAFETY-SEAL valves are used in applications where corrosive, abrasive and toxic media need to be handled and electrostatic charges must be avoided at the same time.



SAFETY-SEAL

MOBILE-SEAL

MOBILE-SEAL valves are used on road tanker vehicles, railway wagons, silos and other transportation and storage containers where high chemical resistance, reliability and special safety requirements are essential. MOBILE-SEAL is EN 14432 approved.



MOBILE-SEAL

Valve Lining

PTFE

Void-free body liner and disc isostatic molded from virgin PTFE. High material density >2.16g/cm³. Guaranteed lining thickness of at least 3mm plus high crystallinity. FDA compliant.

OPERATING TEMPERATURE:

-40°F up to +392°F

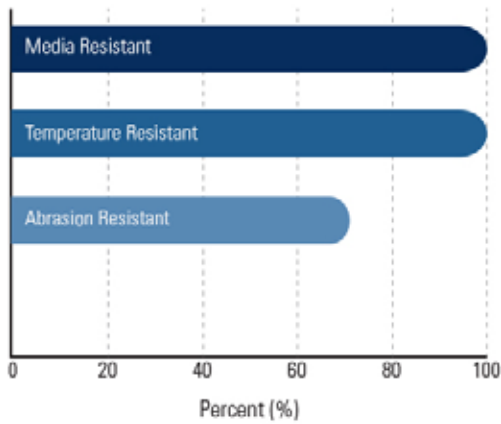

Abrasive PTFE

If the chemical resistance of PTFE is needed along with abrasion resistance, then the use of abrasive service PTFE is recommended. This special PTFE compound is resistant to mechanical wear with almost the same chemical resistance as virgin PTFE.

OPERATING TEMPERATURE:

-40°F up to +392°F

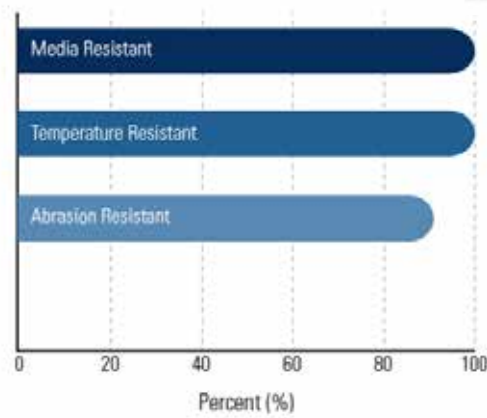

Antistatic PTFE

For explosive environments and medias, this electrostatically conductive lining is available. The service life is comparable to valves lined with PTFE. The material is FDA compliant. TÜV approval. (TÜV 941 F 416 601). Surface resistance ≤ 10⁶ Ω. Volume resistance ≤ 10⁶ Ω cm.

OPERATING TEMPERATURE:

-40°F up to +392°F

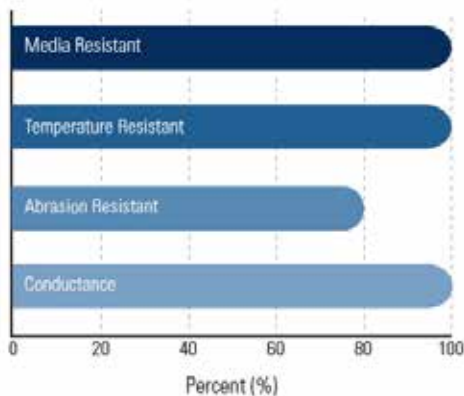

UMPE

Used in extremely abrasive media applications while still offering excellent chemical resistance. Garlock offers a complete, ultra high molecular weight PE (UMPE) liner and encapsulated disc.

OPERATING TEMPERATURE:

-40°F up to +185°F

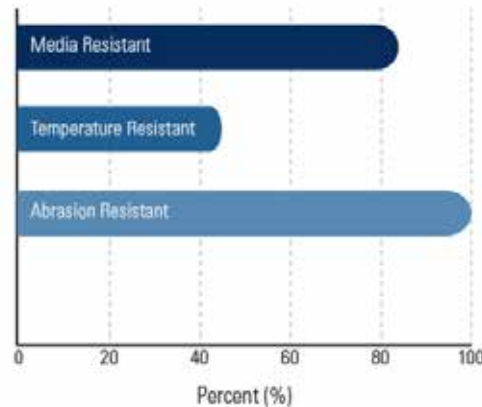

Valve Reliability

SECTION THROUGH THE HEAD FLANGE:

The shaft is sealed against atmospheric pollution and corrosion by two o-rings. TA-Luft compliant sealing is standard. If control connection is needed, it can be integrated to observe the shaft tightness.

BODY

According to the Pressure Equipment Directive Garlock valve bodies are approved by TÜV Rheinland according to DIN 3840 and EN 12516.

FLANGE TYPES

The Gar-Seal valves are available in Wafer and Lug type.

DESIGN

The two piece design of shaft and disc allows for an easy change of the disc and liner. For your convenience the disc and liner can be delivered as a pre assembled set.

SHAFT SEALING

The fully reliable shaft sealing system with Garlock seal rings guarantees tightness over long periods. The shaft sealing system consists of two barriers. The first is an area where disc and liner are pressed together. The second barrier is the Garlock seal ring which includes a PTFE-ring energized by two o-rings. The extensively researched and approved system is completely maintenance free. The structure allows easy maintenance and replacement of disc and liner on site without special tools. The shaft sealing is certified according to "TA-Luft" and exceeds these requirements.

QUALITY ASSURANCE

Garlock valves set the standard in high quality, and the Garlock quality management system is certified according to ISO 9001 and PED 97/23/EC Module H1. Each valve is extensively tested according to EN 12266 before leaving our factory. To ensure absolute traceability of the materials each valve is tagged with a serial number on a stainless steel tag. Based on the serial number, material certificates for body parts, PTFE/UHMWPE resins, shaft and steel disc can be provided. This high standard guarantees absolute quality, control and transparency.

CERTIFICATES AND APPROVALS

- » DIN EN ISO 9001:2008
- » PED 97/23/EC Module H1
- » Material certificate EN 10204 - 3.1
- » Testing according to EN 12266
- » 100% spark test of all PTFE and UHMWPE parts



Materials

HOUSING MATERIALS

The housings of Garlock valves and fittings are manufactured from high-quality ductile cast iron (EN-JS 1049). Depending on the intended use, however, other materials, such as cast steel (1.0619) and stainless steel (1.4581) are also available. All housings are manufactured and inspected in accordance with the specification of the pressure equipment directive.

LINER

Depending on the intended use, a large selection of lining materials are available. To provide reliable seals, PTFE is available in several versions as well as UHMWPE. All lining materials are manufactured by specialists and inspected comprehensively. Your contact for Garlock products will be happy to assist you in selecting the suitable material.

ELASTOMERS

- » Silicone (standard)
- » Viton®
- » EPDM
- » Neoprene

DISC

The disc is also available in different materials depending on application. Along with PTFE and UHMWPE, metal discs made of Stainless Steel, Hastelloy Grade C or Titanium are an option. All discs are manufactured by specialists and inspected comprehensively.

MARKING

Each valve is tagged with a stainless steel plate. All information such as dimension, serial number, type, materials, operating pressure and temperature, flange connection and certification are engraved.



Production

All processes have been defined through our ISO 9001 quality assurance system. The system is regularly reviewed and is being constantly improved. Quality, service and flexibility of the highest order are standard requirements we impose on ourselves and all our suppliers.

With our production facility in Germany and stock all over the world, we are in a position to react to your global requirements in a very short time.

We manufacture each valve according to customer requirements. In doing so, we carry out all necessary configurations as per your specifications.

APPROVALS

- » PED 97/23/EC
- » TA Luft / VDI 2440
- » EN 61508 - SIL 3
- » TR-Certificate
- » Chlorine Approval (RUS)
- » EN 14432 (Mobile Seal)
- » EN 15848-1

CUSTOM-TAILORED SERVICE:

We are happy to help you to find the most suitable product for your particular application. In this respect, we have a high number of standard products available to you. In addition, project planning and design of custom-made solutions for our customers is one of our strengths, where we draw on decades of experience as a global manufacturer of seals and valves.

We offer professional consulting and project planning that is geared for your requirements. You'll benefit from our individual on-site support services which are specifically tailored to meet your company's needs. We conduct training seminars, help optimize inventory, reduce emissions, ensure functionality and prevent costly downtime. Our experienced employees will be happy to assist you at any time.



Test Engineering

TESTING

All our valves are tested according to EN 12266-1 before they are sent out to you. Standard tests are body strength (P10), body tightness (P11) and seat tightness (P12). A functional test is also performed.



DIMENSIONS OF LINER THICKNESS

On all PTFE parts, the liner thickness is checked in accordance with specific measuring methods. The test ensures that the required thicknesses are consistent for all parts. This measurement is indicative of the special attention paid to quality requirements of GAR-SEAL valves.

This guarantees a long and reliable lifetime of PTFE and UHMWPE parts during operation.



To ensure consistent high quality valves all components are subjected to stringent testing running in parallel with all stages of production.

VACUUM

GAR-SEAL valves are suitable for use in a vacuum service. For use in practical applications at elevated temperatures and simultaneously high vacuums there are special vacuum linings with increased wall thickness available.



CONDUCTIVITY

The PTFE body lining and the lining of the disc of the SAFETY-Seal (conductive version) are all checked for the required conductivity.

These measurements are carried out with the resistivity measurement device in accordance with the specific guidelines. This ensures that electrostatic loads are safely discharged during operations.



Standards

FACE-TO-FACE DIMENSIONS

- » ISO 5752 Table 5 short
- » ASME B16.10
(2" to 12" Table Narrow
14" to 24" Table Wide)
- » DIN EN 558-1 GR 20
- » MSS-SP 67
(2" to 12" Table Narrow
14" to 24" Table Wide)
- » API 609
(2" to 12" Category A
14" to 24" Category B)

ADAPTER FLANGE

- » DIN/ ISO 5211
- » NF E 29-402

BODY TYPES

- » Wafer
- » Lug
- » With long neck for insulation in accordance with HeizAnl.V
(German Heating Installations Ordinance)

BODY STRENGTH

- » DIN EN 12516 T2 (DIN 3840), tested within the scope
certification according to PED 97/23/EC Module H1

BODY MATERIALS

- » Spheroidal graphite cast iron
(EN-JS1049, 0.7043)
- » Cast steel (GS-C 25, 1.0619)
- » Stainless steel casting
(G-X5CrNiMoNb 18 10, 1.4581)

SHAFT MATERIALS

- » 1.4313 up through 12"
- » 1.4021 above 12"

FLANGE CONNECTION

- » ASME B16.5 Class 150 lbs
(Design RF, FF)
- » EN 1092 PN 10/16 (Design A/B)
– (Available upon request)

TESTING

- » EN 12266 P10
- » EN 12266 P11
- » EN 12266 P12 Leak rate A

PTFE LINING

- » void-free
- » isostatic pressed
- » high density (min. 2.16 g/cm³)
- » lining thickness min. 3 mm
- » vacuum lining up to 10 mm available

VACUUM TIGHTNESS

- » $q^{He}max < 10^{-6}$ mbar 1·s⁻¹

IDENTIFICATION

- » DIN EN 19
- » AD 2000 data sheet A4

VALVE DISC ALIGNMENT

- » Centrally, i.e. energy-saving

CHARACTERISTIC

- » Linear

Material Selection

Valve Material						Design Type					
1 Valve Body		2 Body Liner		3 Disc		4 Specific Design Body Liner		5 Valve Type		6 Body Type	
Code	Material	Code	Material	Code	Material	Code	Material	Code	Material	Code	Material
1	Ductile Cast Iron EN-JS 1049 (0.7043)	1	PTFE**	1	PTFE**	A	Antistatic (SAFETY-SEAL)	V	Vacuum	W	WAFER Ring Body
2	Cast Steel GS-C 25 (1.0619)	2	UHMWPE***	2	UHMWPE***	C	abrasive service	SV	Special vacuum	L	LUG Flange-on-Body
3	Stainless Steel (1.4581)			3	Stainless Steel (1.4581)	S	STERILE-SEAL				MOBILE-SEAL
				4	Hastelloy C* (2.4602)					Code	With existing pipe flanges
				5	Titanium* (3.7035)					W-T	MOBILE-SEAL Wafer
										L-T	MOBILE-SEAL Lug
										W-WT	MOBILE-SEAL Drilling according to DIN 28459

Examples	1	2	3	4	5	6	
GAR-SEAL, WAFER Design	1	1	1	-	-	W	MT
SAFETY-SEAL, LUG Design	3	1	1	A	-	L	MT
MOBILE-SEAL, WAFER Design, acc. to TW standard	1	1	1	-	-	W-WT	MT
STERILE-SEAL, LUG Design, antistatic	3	1	3	S	-	L	
SAFETY-SEAL, WAFER Design, antistatic	2	1	1	A	-	W	MT
GAR-SEAL, WAFER Design vacuum lining	1	1	1	-	V	W	MT

Performance Data

- 2" - 24"
- Nominal Pressure
max. 232 psi (<12")
up to full vacuum
(depending upon temperature)
- Operating temperature
-40°F to +392°F (for PTFE**)
-40°F to +185°F (for UHMWPE***)
- MT = GAR-SEAL Butterfly Valves
comply with the TA-Luft regulations.

* upon request
 ** Polytetrafluorethylene
 *** Ultrahighmoleculare Polyethylene

All information and recommendations contained in this catalogue are based on many years of experience and the current state of technology. Unknown factors may, however, limit generally accepted knowledge. Binding statements regarding the compatibility of our products are therefore possible only after practical onsite tests under operating conditions. Information contained in our catalog does therefore not constitute or imply any representation of warranty. While the utmost care has been used in compiling this catalogue, we assume no responsibility for errors. Specifications subject to change without notice. This edition cancels all previous issues. Subject to change without notice.

Applications

GAR-SEAL

GAR-SEAL butterfly valves are used where corrosive, abrasive and toxic media need to be controlled. GAR-SEAL valves are used for controlling, throttling and shutting off purposes in the chemical, petrochemical and chlorine industry as well as in electroplating, the paper industry and many other industries.

DIMENSIONS

- » 2" up to 24"

FLANGE CONNECTION

- » ASME B16.5 class 150 lbs (design RF/FF)
- » EN 1092 PN 10/16 (Design A/B)
 - (Available upon request)

FACE-TO-FACE DIMENSIONS

- » ISO 5752 Table 5 short
- » ASME B16.10
 - (2" to 12" Table Narrow)
 - (14" to 24" Table Wide)
- » DIN EN 558-1 GR 20
- » MSS-SP 67
 - (2" to 12" Table Narrow)
 - (14" to 24" Table Wide)
- » API 609
 - (2" to 12" Category A)
 - (14" to 24" Category B)

BODY STRENGTH

- » DIN/ EN 12516 T2 (DIN 3840)
- » tested within the scope of the inspection body designate by Module H1

OPERATING PRESSURE

- » 2" - 12" 232 psi
- » above 12" 150 psi (depending on operating temperature)



TESTING

- » EN 12266 P10
- » EN 12266 P11
- » EN 12266 P12 Leak rate A

BODIES

- » Wafer and Lug design with long neck for insulation

VACUUM

- » up to 1 mbar abs. (depending on size and temperature)

TEMPERATURE RANGE

- » -40 °F up to +392 °F (depending on material)

HEAD FLANGE

- » EN ISO 5211
- » NF E 29-402

LINER

- » PTFE
- » Abrasive PTFE
- » UHMWPE

Applications

SAFETY-SEAL

SAFETY-SEAL valves are used in applications where corrosive, abrasive and toxic media need to be insulated against electrostatic charges.

SAFETY-SEAL valves offer long life and reduced maintenance efforts and extra safety.



DIMENSIONS

- » 2" up to 24"

FLANGE CONNECTION

- » ASME B16.5 class 150 lbs (design RF/FF)
- » EN 1092 PN 10/16 (Design A/B)
 - (Available upon request)

FACE-TO-FACE DIMENSIONS

- » ISO 5752 Table 5 short
- » ASME B16.10
 - (2" to 12" Table Narrow)
 - (14" to 24" Table Wide)
- » DIN EN 558-1 GR 20
- » MSS-SP 67
 - (2" to 12" Table Narrow)
 - (14" to 24" Table Wide)
- » API 609
 - (2" to 12" Category A)
 - (14" to 24" Category B)

BODY STRENGTH

- » DIN/ EN 12516 T2 (DIN 3840)
- » tested within the scope of the inspection body designate by Module H1

OPERATING PRESSURE

- » 2" - 12" 232 psi
- » above 12" 150 psi (depending on operating temperature)

TESTING

- » EN 12266 P10
- » EN 12266 P11
- » EN 12266 P12 Leak rate A

BODIES

- » Wafer and Lug design with long neck for insulation

VACUUM

- » up to 1 mbar abs. (depending on size and temperature)

TEMPERATURE RANGE

- » -40 °F up to +392 °F (depending on material)

HEAD FLANGE

- » EN ISO 5211
- » NF E 29-402

LINER

- » Antistatic PTFE

Applications

MOBILE-SEAL

MOBILE-SEAL valves are used on road tanker vehicles, railway wagons, silos and other transportation and storage containers where high chemical resistance, reliability and special safety requirements are essential.

DIMENSIONS

- » 2" up to 24"

FLANGE CONNECTION

- » ASME B16.5 class 150 lbs (design RF/FF)
- » EN 1092 PN 10/16 (Design A/B)
- » DIN 28459 PN10
 - (Available upon request)

FACE-TO-FACE DIMENSIONS

- » ISO 5752 Table 5 short
- » ASME B16.10 (2" to 4" Table Narrow)
- » DIN EN 558-1 GR 20
- » MSS-SP 67 (2" to 4" Table Narrow)
- » API 609 (2" to 14" Category A)

BODY STRENGTH

- » DIN/ EN 12516 T2 (DIN 3840)
- » tested within the scope of the inspection body designate by Module H1

OPERATING PRESSURE

- » 2" - 4" 150 psi (depending on operating temperature)

TESTING

- » EN 12266 P10
- » EN 12266 P11
- » EN 12266 P12 Leak rate A



BODIES

- » Wafer and Lug design with long neck for insulation

VACUUM

- » up to 1 mbar abs. (depending on size and temperature)

TEMPERATURE RANGE

- » -40 °F up to +392 °F (depending on material)

HEAD FLANGE

- » EN ISO 5211
- » NF E 29-402

LINER

- » PTFE

Materials

GAR-SEAL, SAFETY-SEAL, MOBILE-SEAL

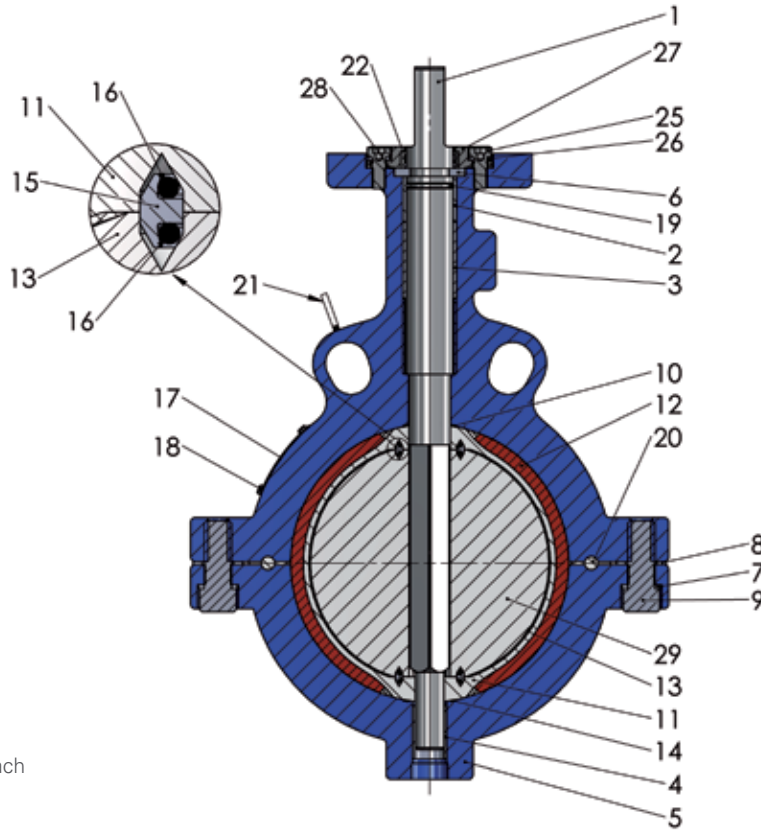

- ¹ does not apply above 10"
- ² Dimensions > 14" - 4 pieces each
- ³ Special design
- ⁴ other materials on request

Pos.	Qty	Material	Designation	Pos.	Qty	Material	Designation
1	1	1.4313 up to 12" 1.4021 above 12"	Shaft	15	2	PTFE	Seal ring
2	1	Steel/PTFE	Slide bearing (top)	16	4 ⁴	Viton	O-Ring (seal ring)
3	2	Steel/PTFE	Slide bearing (center)	17	1	Stainless Steel	Nameplate
4	1	Steel/PTFE	Slide bearing (bottom)	18	4	Stainless Steel	Rivet
5	1	see material table	Body	19	1 ⁴	Viton	O-Ring
6	1 ¹	PTFE, carbon reinf.	Retaining ring (split)	20	2	PTFE	Security element
7	2 ²	Stainless Steel	Spring washer	21	1 ³	Steel electrostop	Ground connection
8	2 ²	GYLON®	Washer	22	2 ⁴	Viton	O-Ring (adapter flange)
9	2 ²	Stainless Steel	Body screw				
10	1	GYLON®	Top gasket	25	4	Stainless Steel	Screw
11	1	see material table	Lining	26	4	Stainless Steel	Spring washer
12	2 ⁴	Silicone	Elastomer backup element	27	1	Stainless Steel	Adapter flange
13	1	see material table	Disc	28	1	GYLON®	Seal (adapter flange)
14	1	GYLON®	Bottom gasket	29	1	0.7040 (GGG 40)	Disc insert (only PTFE & UHMWPE lined disc)

Dimensions, Wafer

GAR-SEAL, SAFETY-SEAL, MOBILE-SEAL

Flange connection: ANSI B 16.5, 150 lbs.
 Overall length: ASME B16.10
 Adapter flange: EN ISO 5211

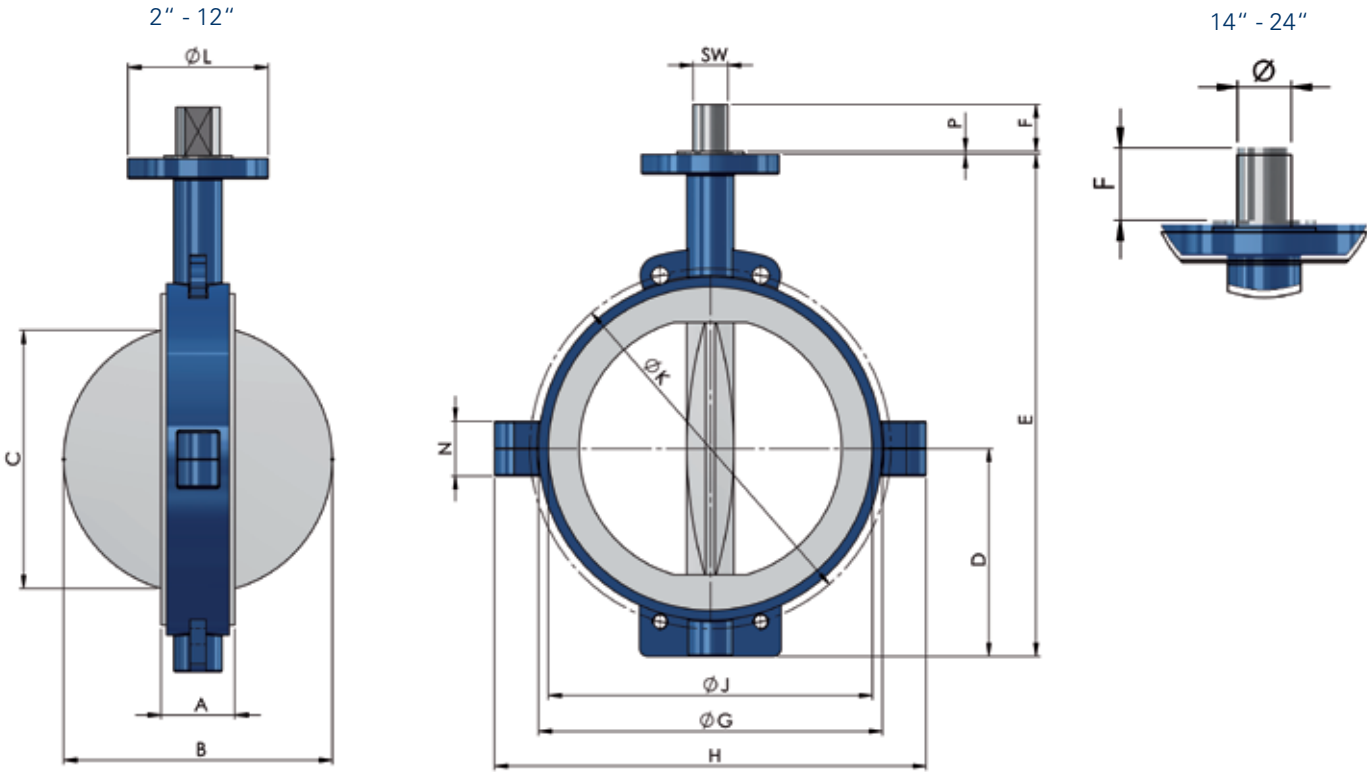

Size Inch	Adapter flange **	A	B	C	D	E	F	G	H	J	K	L	SW Ø	P	N	Weight lb
2	F05	1.7	2.4	1.7	2.4	7.9	1.4	4.0	5.9	3.9	4.4	2.6	0.4	0.1	1.6	5.7
2 ½	F05	1.8	2.8	2.1	2.8	8.7	1.4	4.8	6.8	4.7	5.5	2.6	0.4	0.1	1.6	7.9
3	F05	1.8	3.2	2.6	3.6	10.1	1.4	5.2	7.2	5.0	5.9	2.6	0.4	0.1	1.6	8.9
4	F07	2.0	4.2	3.7	4.3	11.4	1.4	6.4	8.4	6.3	7.5	3.5	0.5	0.1	1.9	13.5
5	F07	2.2	5.0	4.5	4.7	12.4	1.4	7.6	9.8	7.4	8.5	3.5	0.5	0.1	1.9	18.9
6	F10	2.2	6.2	5.8	5.4	13.8	1.6	8.6	11.4	8.5	9.5	4.9	0.7	0.1	2.2	24.7
8	F10	2.4	7.8	7.4	6.4	16.1	1.6	10.8	13.8	10.6	11.7	4.9	0.7	0.1	2.2	36.2
10	F12	2.7	9.7	9.3	7.9	18.9	1.9	12.9	15.9	12.8	14.3	5.9	0.9	0.1	2.4	59.9
12	F12	3.1	11.6	11.2	9.2	21.8	1.9	14.9	17.9	14.8	17.0	5.9	0.9	0.1	2.8	79.6
14	F14	3.6	13.2	12.7	10.4	25.2	2.4	17.3	21.7	16.3	18.7	6.9	1.7	0.2	2.8	157.7
16	F14	4.0	15.2	14.7	12.0	28.5	2.4	19.3	22.4	18.5	21.3	6.9	1.7	0.2	2.8	196.7
18	F16	4.5	16.9	16.3	12.6	30.7	3.2	21.2	26.4	20.9	22.8	8.3	1.7	0.2	2.8	276.5
20	F16	5.0	19.1	18.4	14.4	34.5	3.2	23.4	27.2	22.9	25.0	8.3	1.7	0.2	2.8	346.9
24	F25	6.1	22.8	21.9	16.3	38.9	3.5	27.4	32.3	27.2	29.5	11.8	2.5	0.2	2.9	564.9

GAR-SEAL + SAFETY-SEAL MOBILE-SEAL

Dimensions, Lug

GAR-SEAL, SAFETY-SEAL, MOBILE-SEAL

Flange connection: ANSI B 16.5, 150 lbs.
 Overall length: ASME B16.10
 Adapter flange: EN ISO 5211

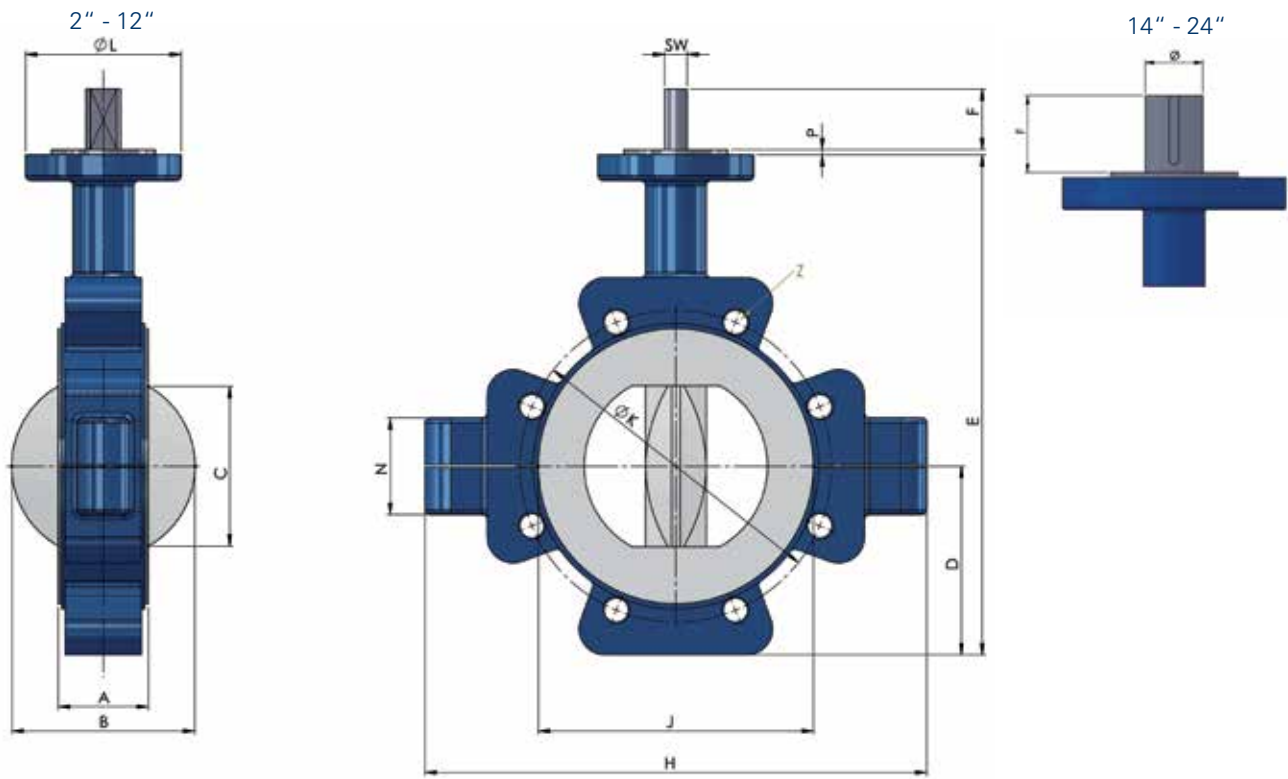

GAR-SEAL + SAFETY-SEAL MOBILE-SEAL

Size Inch	Adapter flange **	A	B	C	D	E	F	H	J	K	L	SW Ø	P	N	Z	Weight lb
2	F05	1.7	2.4	1.7	2.4	7.9	1.4	6.7	3.9	4.8	2.6	0.4	0.1	1.8	4x ⁵ / ₈ "-11	7.5
2 ½	F05	1.8	2.8	2.1	2.8	8.7	1.4	7.6	4.7	5.5	2.6	0.4	0.1	1.8	4x ⁵ / ₈ "-11	9.5
3	F05	1.8	3.2	2.6	3.6	10.1	1.4	9.9	5.0	5.9	2.6	0.4	0.1	2.2	4x ⁵ / ₈ "-11	14.3
4	F07	2.0	4.2	3.7	4.3	11.4	1.4	11.4	6.3	7.5	3.5	0.5	0.1	2.2	8x ⁵ / ₈ "-11	22.5
5	F07	2.2	5.0	4.5	4.7	12.4	1.4	12.3	7.4	8.5	3.5	0.5	0.1	2.4	8x ³ / ₄ "-10	27.8
6	F10	2.2	6.2	5.8	5.4	13.8	1.6	14.3	8.5	9.5	4.9	0.7	0.1	2.6	8x ³ / ₄ "-10	35.5
8	F10	2.4	7.8	7.4	6.4	16.1	1.6	16.4	10.6	11.7	4.9	0.7	0.1	2.9	8x ³ / ₄ "-10	49.4
10	F12	2.7	9.7	9.3	7.9	18.9	1.9	20.0	12.8	14.3	5.9	0.9	0.1	3.5	12x ⁷ / ₈ "-9	81.4
12	F12	3.1	11.6	11.2	9.2	21.8	1.9	22.6	14.8	17.0	5.9	0.9	0.1	4.3	12x ⁷ / ₈ "-9	115.8
14	F14	3.6	13.2	12.7	10.4	25.2	2.4	25.2	16.3	18.7	6.9	1.7	0.2	2.8	12x 1"-8	226.0
16	F14	4.0	15.2	14.7	12.0	28.5	2.4	28.3	18.5	21.3	6.9	1.7	0.2	2.8	16x 1"-8	290.4
18	F16	4.5	16.9	16.3	12.6	30.7	3.2	29.5	20.9	22.8	8.3	1.7	0.2	2.8	16x1 ¹ / ₈ "-7	339.4
20	F16	5.0	19.1	18.4	14.4	34.5	3.2	32.7	22.9	25.0	8.3	1.7	0.2	2.8	20x1 ¹ / ₈ "-7	546.4
24	F25	6.1	22.8	21.9	16.3	38.9	3.5	37.8	27.2	29.5	11.8	2.5	0.2	2.9	20x1 ¹ / ₄ "-7	850.5

Exploded View

GAR-SEAL

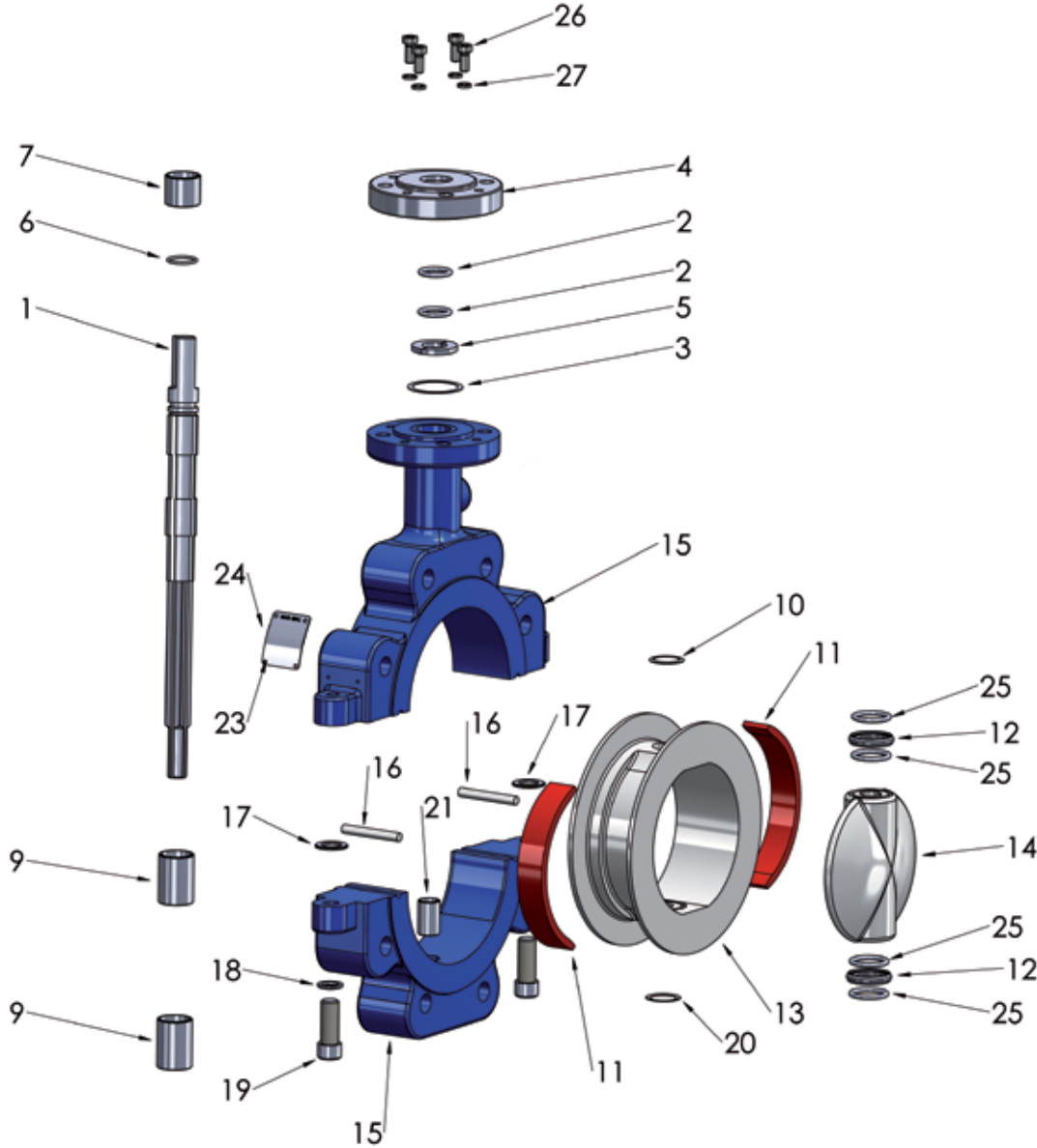

Pos.	Designation	Pos.	Designation	Pos.	Designation	Pos.	Designation
1	Shaft	9	Slide bearing (center)	16	Security element	24	Name plate
2	O-Ring (shaft)	10	O-Ring (liner)	17	Washer	25	O-Ring (sealing)
3	O-Ring (top flange)	11	Elastomere back-up	18	Spring washer	26	Locking screw
4	Top flange	12	Seal ring	19	Body screw	27	Spring washer
5	Retaining ring (split)	13	Liner	20	O-ring (liner)		
6	O-Ring (shaft)	14	Disc	21	Slide bearing (bottom)		
7	Slide bearing (top)	15	Body	23	Groove pin		

* Special Design

STERILE-SEAL

APPLICATIONS

STERILE-SEAL valves are used where sterile processes need to be maintained in the pharmaceutical and food industries without unnecessary and costly overhauls and replacement.

The special characteristic of this valve is its external sterilization capability. By the design of the valve the critical "dead" areas of the valve, as well as the disc, body liner and seals, can be sterilized with steam without contact to the process.



DIMENSIONS

- » 2" up to 16"

FLANGE CONNECTION

- » ASME B16.5 class 150 lbs (design RF/FF)
- » EN 1092 PN 10/16 (Design A/B)
 - (Available upon request)

FACE-TO-FACE DIMENSIONS

- » ISO 5752 Table 5 short
- » ASME B16.10
(2" to 12" Table Narrow 14" to 24" Table Wide)
- » DIN EN 558-1 GR 20
- » MSS-SP 67
(2" to 12" Table Narrow 14" to 24" Table Wide)
- » API 609
(2" to 12" Category A 14" to 24" Category B)

BODY STRENGTH

- » DIN/ EN 12516 T2 (DIN 3840)
- » tested within the scope of the inspection body designate by Module H1

OPERATING PRESSURE

- » 150 psi (depending on operating temperature)

TESTING

- » EN 12266 P10
- » EN 12266 P11
- » EN 12266 P12 Leak rate A

BODIES

- » Wafer and Lug design with long neck for insulation

VACUUM

- » up to 1 mbar abs. (depending on size and temperature)

TEMPERATURE RANGE

- » -40 °F up to +338 °F (depending on material)

HEAD FLANGE

- » EN ISO 5211
- » NF E 29-402

LINER

- » PTFE

STERILE-SEAL

BACTERIA WON'T SURVIVE

For fermentation, sterile processing is the premise to guarantee the optimum productivity of the microorganisms being used. All bacteria have to be destroyed before fermentation and also all products fed into the process have to be sterilized. Most important is the avoidance of any contamination during fermentation up to the separation of the biomass and treatment of the final product.

CONSTRUCTION

The media in the inner chamber is protected against contamination by the surrounding isolation chambers which are directly connected to the inner sealing system. A second outer sealing system separates the process from the atmosphere. STERILE-SEAL valves are completely void and cavity-free to prevent any build-up of nutrients.

OPERATION PRINCIPLE

Pressurised steam is fed into the steam inlet and distributed through the longitudinal channels of the shaft and out through the flow control at the bottom of the valve body. It is also possible to seal the valve by pressuring the isolation chambers and closing the steam outlet connection.

STERILIZATION PROOF

During tests, STERILE-SEAL valves were contaminated at several points with *Bacillus Stearothermophilus* with a population of $5,7 \times 10^5$. Pressurised steam was then allowed to flow through the two chambers, followed by sterile air. In every instance the bacillus was completely destroyed.

THE SAFE CONCEPT

STERILE-SEAL valves meet the highest standards of Garlock's excellence.

The new re-designed STERILE-SEAL valve with its steam blocking chambers surround and protect the product area against external pollution, even under vacuum conditions. This design is a major breakthrough for large scale biotechnology plants. With the STERILE-SEAL valve bacteria contamination is a thing of the past.

FOR EXAMPLE:

BODY

Split-body, manufactured from ductile iron, cast steel or stainless steel. Safety sealing between the two body halves, seals are fitted within the body liner to prevent atmospheric contamination and the escape of media.

Body liner manufactured from high density PTFE* FDA approved Void-free, impermeable, liner thickness 3 mm minimum.

STAINLESS STEEL DISC

For highest demands, i.e. pyrogenic resistant, particle and fibrous free surfaces with max. 1 % delta-ferrite, content: Forged (WN 1.4435 and others). Surface finishes to $0,1 \mu\text{m Ra}$ are available.

SHAFT

One-piece manufactured from stainless steel with ring and longitudinal channels. The STERILE-SEAL concept improves the profitability of production processes in pharmaceutical, food and biotechnology industries.

ADVANTAGES

- » Safety against contamination
- » Safety against corrosion
- » Safety of the body against over-pressurisation
- » Safety by standardization
- » Safety against leakages
- » Safety by identification

STERILE-SEAL

2 CHAMBER SYSTEM GUARANTEES PRODUCT SAFETY

PTFE*, isostatically molded. High density, high crystallinity, stainless steel discs. STERILE-SEAL valves are available in wafer and lug design in all sizes from 2" to 16". Actuators of any kind and type can be mounted.

SERVICE PRESSURE: From vacuum up to 150 psi

SERVICE TEMPERATURE: 40°F to 338°F (392°F**)

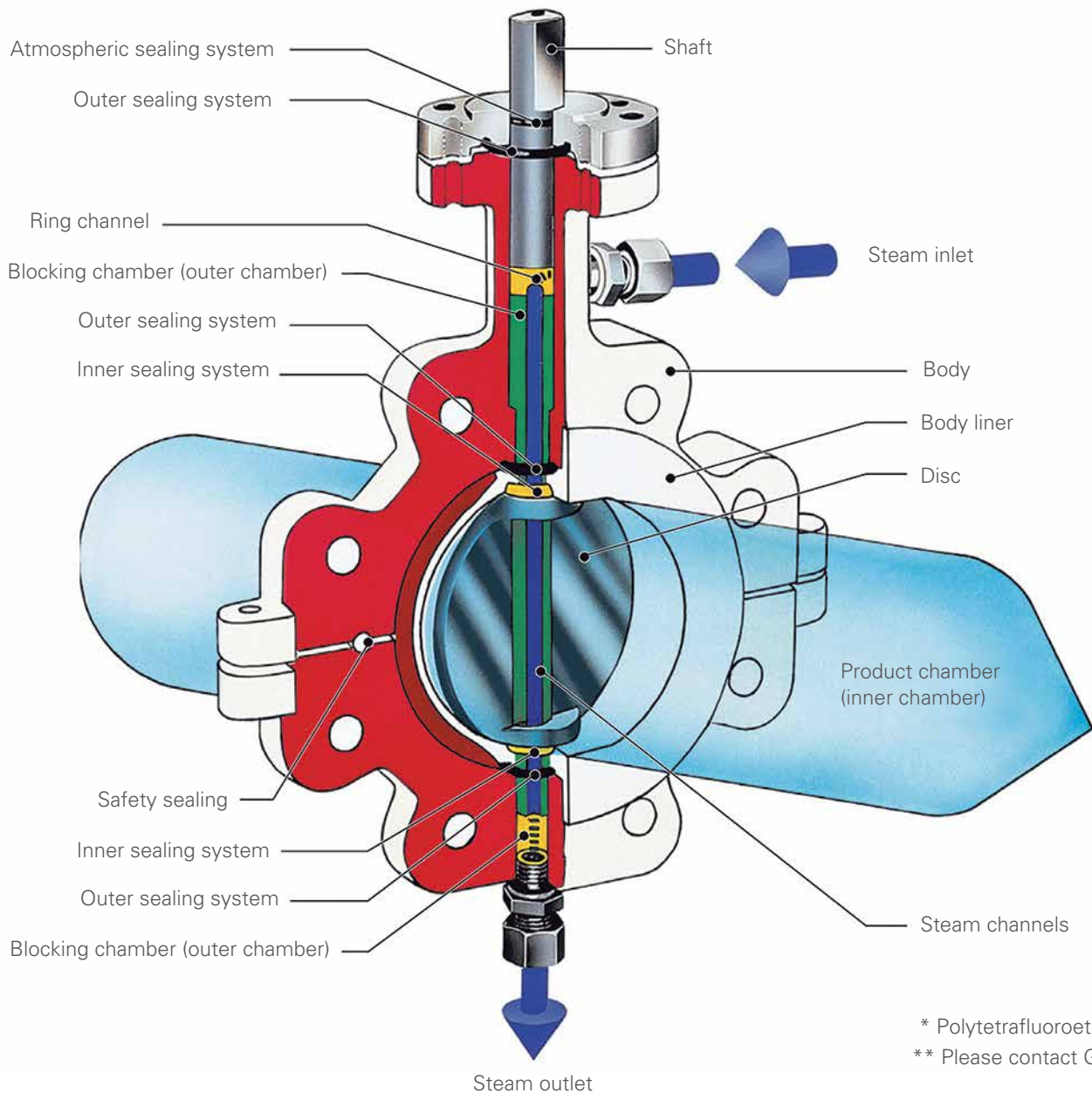

* Polytetrafluoroethylene

** Please contact Garlock

Materials

STERILE-SEAL

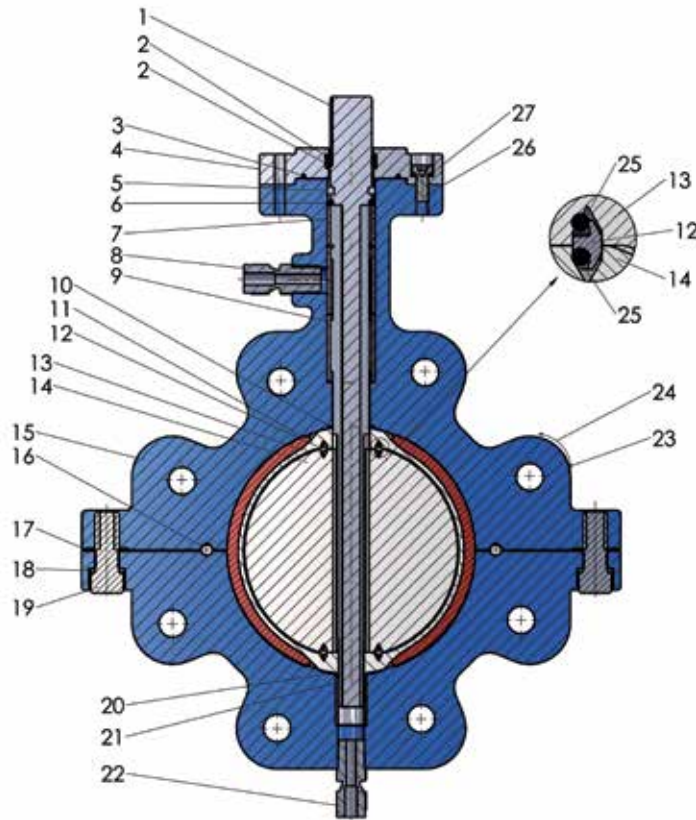

Pos.	Qty	Material	Designation	Pos.	Qty	Material	Designation
1	1	1.4313 up to 12" 1.4021 above 12"	Shaft	14	1	see material table	Valve disc
2	2 ⁴	EPDM	O-ring (shaft)	15	1	s. table	Body
3	1 ⁴	EPDM	O-ring (top flange)	16	2	PTFE	security element
4	1	1.4301	Top flange	17	2	PTFE	washer
5	1	PTFE, carbon reinf.	Retaining ring (split)	18	2	Stainless Steel	Spring washer
6	1 ⁴	EPDM	O-ring (shaft)	19	2	Stainless Steel	Body Screw
7	1	Steel/PTFE	Slide bearing (top)	20	1 ⁴	EPDM	O-ring (liner)
8	1	GYLON [®]	Fitting	21	1	Steel/PTFE	slide bearing (bottom)
9	2	Stainless Steel	Slide bearing (center)	22	1	Stainless Steel	Fitting
10	1 ⁴	EPDM	O-ring (liner)	23	4	Stainless Steel	Groove pin
11	2 ⁴	EPDM	Elastomer backup element	24	1	Stainless Steel	Nameplate
12	2	PTFE	Sealring	25	4 ⁴	EPDM	O-ring (sealing)
13	1	see material table	Liner	26	4	Stainless Steel	Locking screw
				27	4	Stainless Steel	Spring washer

¹ does not apply above 10"

² > 14" - 4 pc. each

³ Special design

⁴ other materials on request

Dimension, Wafer

STERILE-SEAL

Flange connection: ANSI B 16.5, 150 lbs.
 Overall length: EN 558-1 GR20 (DIN 3202 T3 K1)
 Adapter flange: EN ISO 5211

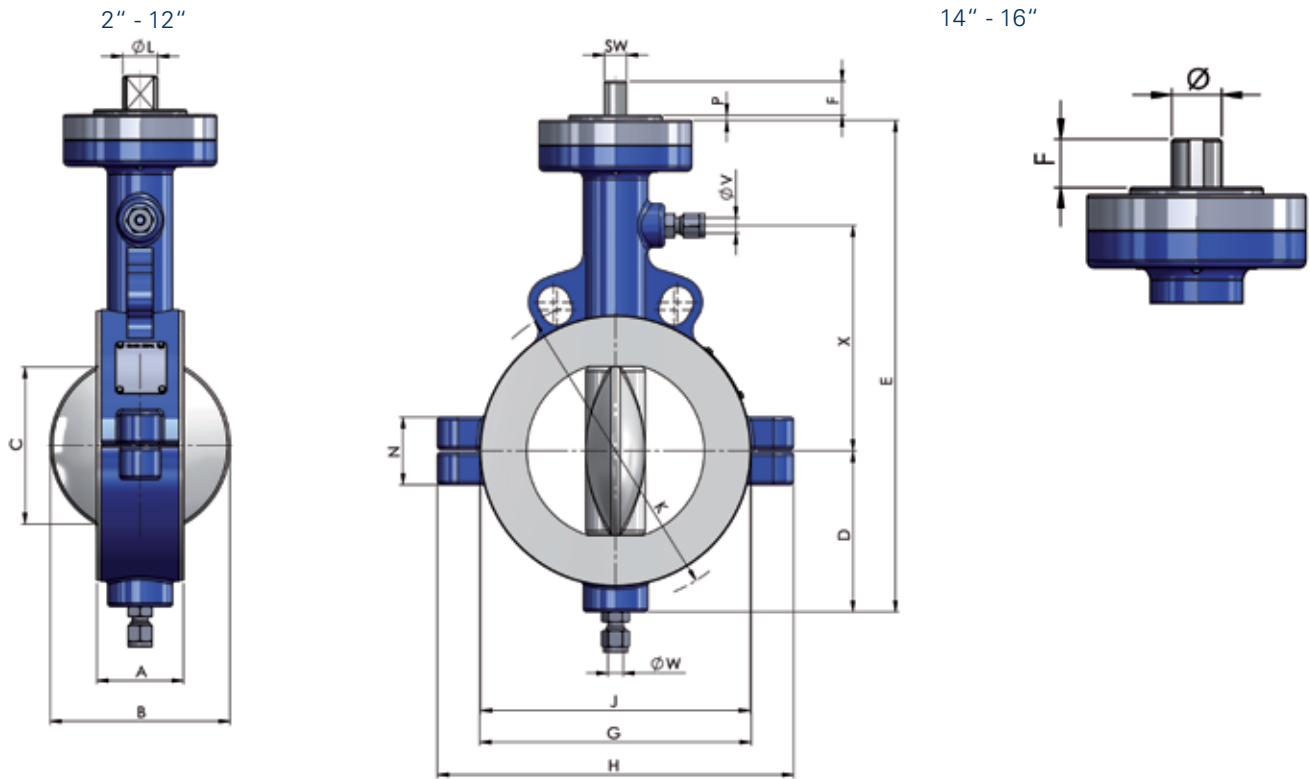

Size Inch	Adapter flange **	A	B	C	D	E	F	G	H	J	K	L	SW Ø	P	N	ØV (mm)	ØW (mm)	X	Weight lb
2	F05	1.7	2.4	1.7	2.4	7.9	1.4	4.0	6.0	3.9	4.8	2.6	0.4	0.1	1.8	10	10	4.1	7.5
2 ½	F05	1.8	2.8	2.1	2.8	8.7	1.4	4.8	7.1	4.7	5.5	2.6	0.4	0.1	1.8	12	12	4.4	9.5
3	F05	1.8	3.2	2.6	3.6	10.1	1.4	5.2	7.2	5.0	5.9	2.6	0.4	0.1	2.2	12	12	5.0	14.3
4	F07	2.0	4.2	3.7	4.3	11.4	1.4	6.4	8.4	6.3	7.5	3.5	0.5	0.1	2.2	12	12	5.2	22.5
5	F07	2.2	5.0	4.5	4.7	12.4	1.4	7.6	9.8	7.4	8.5	3.5	0.5	0.1	2.4	12	12	5.8	27.8
6	F10	2.2	6.2	5.8	5.4	13.8	1.6	8.6	11.4	8.5	9.5	4.9	0.7	0.1	2.6	12	12	6.6	35.5
8	F10	2.4	7.8	7.4	6.4	16.1	1.6	10.7	13.8	10.6	11.7	4.9	0.7	0.1	2.9	12	12	7.8	49.4
10	F12	2.7	9.7	9.3	7.9	18.9	1.9	12.9	15.9	12.8	14.3	5.9	0.9	0.1	3.5	18	18	9.0	81.4
12	F12	3.1	11.6	11.2	9.2	21.8	1.9	14.9	17.9	14.8	17.0	5.9	0.9	0.1	4.3	18	18	10.2	115.8
14	F14	3.6	13.2	12.7	10.4	25.2	2.4	17.2	21.7	16.3	18.7	6.9	1.7	0.2	2.8	25	25	12.4	226.0
16	F14	4.0	15.2	14.7	12.0	28.5	2.4	19.2	22.4	18.5	21.3	6.9	1.7	0.2	2.8	25	25	14.1	290.4

Dimension, Lug

STERILE-SEAL

Flange connection: ANSI B 16.5, 150 lbs.
 Overall length: EN 558-1 GR20 (DIN 3202 T3 K1)
 Adapter flange: EN ISO 5211
 2" to 16"

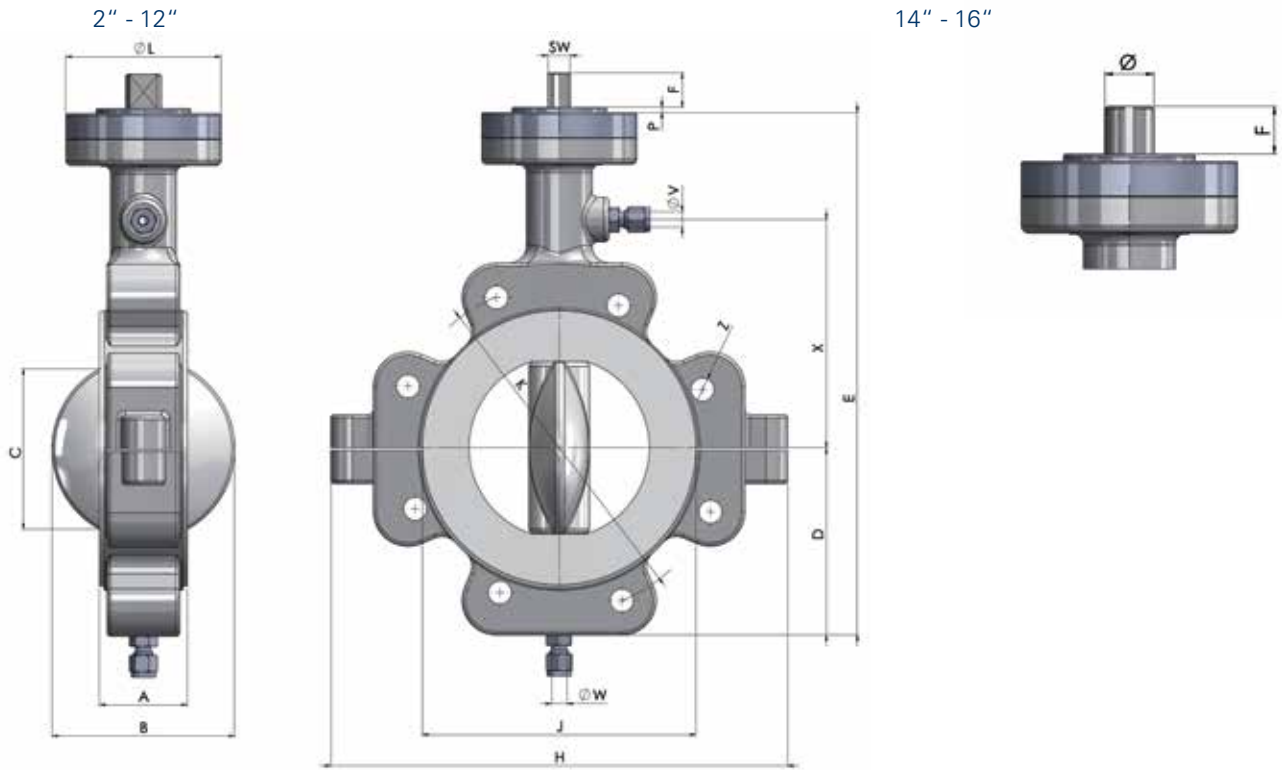

Size Inch	Adapter flange **	A	B	C	D	E	F	H	J	K	L	SW Ø	P	N	ØV (mm)	ØW (mm)	Z	X	Weight lb
2	F05	1.7	2.4	1.7	2.4	7.9	1.4	6.0	3.9	4.8	2.6	0.4	0.1	1.8	10	10	4x ⁵ / ₈ "-11	4.1	7.5
2 ½	F05	1.8	2.8	2.1	2.8	8.7	1.4	7.1	4.7	5.5	2.6	0.4	0.1	1.8	12	12	4x ⁵ / ₈ "-11	4.4	9.5
3	F05	1.8	3.2	2.6	3.6	10.1	1.4	7.2	5.0	5.9	2.6	0.4	0.1	2.2	12	12	4x ⁵ / ₈ "-11	5.0	14.3
4	F07	2.0	4.2	3.7	4.3	11.4	1.4	8.4	6.3	7.5	3.5	0.5	0.1	2.2	12	12	8x ⁵ / ₈ "-11	5.2	22.5
5	F07	2.2	5.0	4.5	4.7	12.4	1.4	9.8	7.4	8.5	3.5	0.5	0.1	2.4	12	12	8x ³ / ₄ "-10	5.8	27.8
6	F10	2.2	6.2	5.8	5.4	13.8	1.6	11.4	8.5	9.5	4.9	0.7	0.1	2.6	12	12	8x ³ / ₄ "-10	6.6	35.5
8	F10	2.4	7.8	7.4	6.4	16.1	1.6	13.8	10.6	11.7	4.9	0.7	0.1	2.9	12	12	8x ³ / ₄ "-10	7.8	49.4
10	F12	2.7	9.7	9.3	7.9	18.9	1.9	15.9	12.8	14.3	5.9	0.9	0.1	3.5	18	18	12x ⁷ / ₈ "-9	9.0	81.4
12	F12	3.1	11.6	11.2	9.2	21.8	1.9	17.9	14.8	17.0	5.9	0.9	0.1	4.3	18	18	12x ⁷ / ₈ "-9	10.2	115.8
14	F14	3.6	13.2	12.7	10.4	25.2	2.4	21.7	16.3	18.7	6.9	1.7	0.2	2.8	25	25	12x 1"-8	12.4	226.0
16	F14	4.0	15.2	14.7	12.0	28.5	2.4	22.4	18.5	21.3	6.9	1.7	0.2	2.8	25	25	16x 1"-8	14.1	290.4

Exploded View

STERILE-SEAL

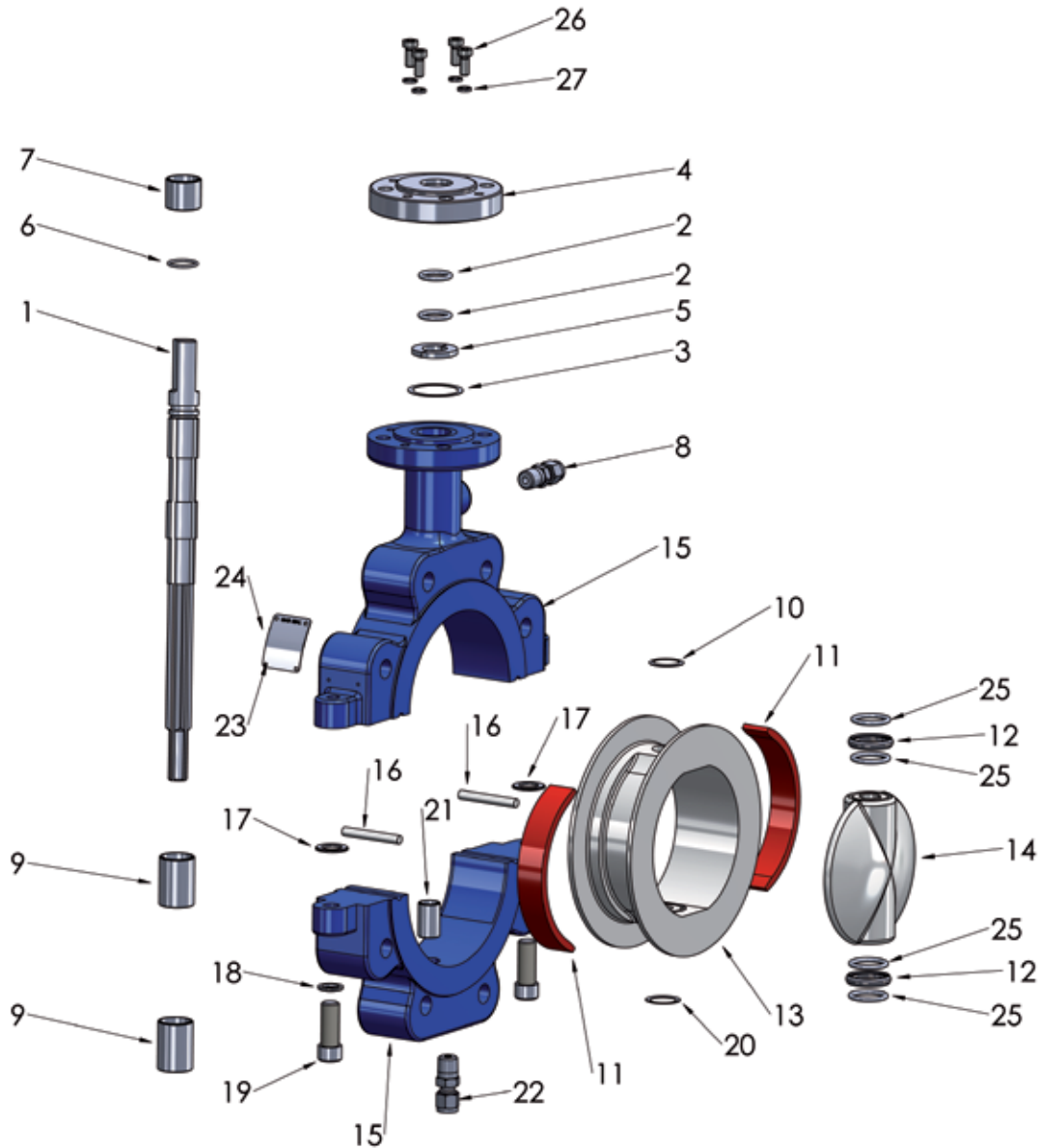

Pos.	Designation	Pos.	Designation	Pos.	Designation	Pos.	Designation
1	Shaft	8	Fitting	15	Body	22	Fitting
2	O-Ring (shaft)	9	Slide bearing (center)	16	Security element	23	Groove pin
3	O-Ring (top flange)	10	O-Ring (liner)	17	Washer	24	Name plate
4	Top flange	11	Elastomere back-up	18	Spring washer	25	O-Ring (sealing)
5	Retaining ring (split)	12	Seal ring	19	Body screw	26	Locking screw
6	O-Ring (shaft)	13	Liner	20	O-ring (liner)	27	Spring washer
7	Slide bearing (top)	14	Disc	21	Slide bearing (bottom)		

* Special Design

Mounting flange

LUG + WAFER, MOBILE-SEAL, GAR-SEAL, SAFETY-SEAL, STERILE-SEAL

According to ISO 5211

2" - 12"

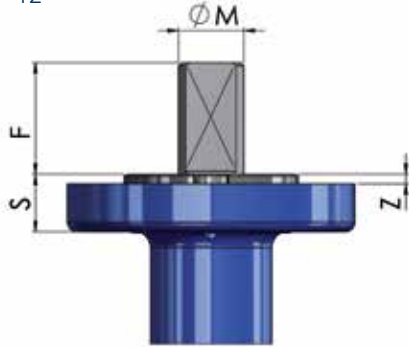

12" - 24"

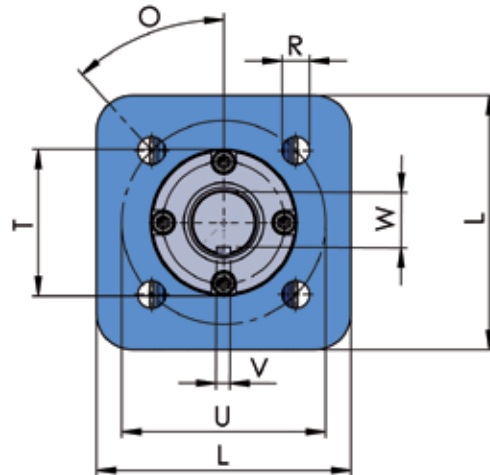
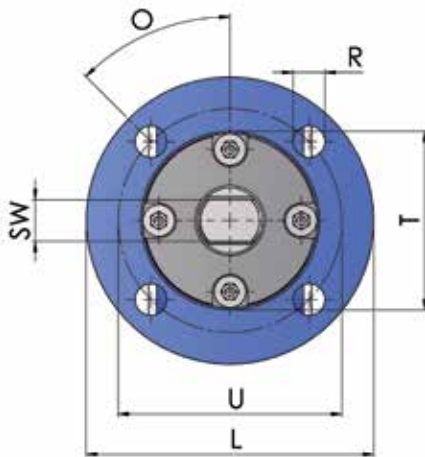
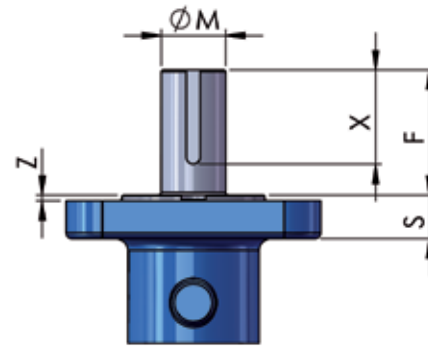

Size Inch	Adapter flange EN ISO 5211	F	SW	L	Ø M	O	n x R # x mm	S*	S**	U	T	Z	V	W	X
2/2½/3	F05	1.4	0.4	2.6	0.6	45°	4 x 7	0.6	1.1	1.9	1.4	0.1	-	-	-
4/5	F07	1.4	0.5	3.5	0.8	45°	4 x 9	0.7	1.3	2.8	2.2	0.1	-	-	-
6/8	F10	1.6	0.7	4.9	1.0	45°	4 x 11	0.7	1.3	4.0	2.8	0.1	-	-	-
10/12	F12	1.9	0.9	5.9	1.3	45°	4 x 13	0.8	1.4	4.9	3.3	0.1	-	-	-
14/16	F14	2.4	-	6.9	1.7	45°	4 x 17	1.3	2.5	5.5	3.9	0.2	0.4	1.5	2.2
18/20	F16	3.1	-	8.3	1.7	45°	4 x 22	1.7	-	6.5	5.1	0.2	0.4	1.5	2.2
24	F25	3.5	-	11.8	2.5	22,5°	8 x 17	2.4	-	10.0	7.9	0.2	0.6	2.1	2.8

* GAR-SEAL, SAFETY-SEAL, MOBILE-SEAL

** STERILE-SEAL

Hand-Lever

LUG + WAFER, GAR-SEAL, SAFETY-SEAL, STERILE-SEAL

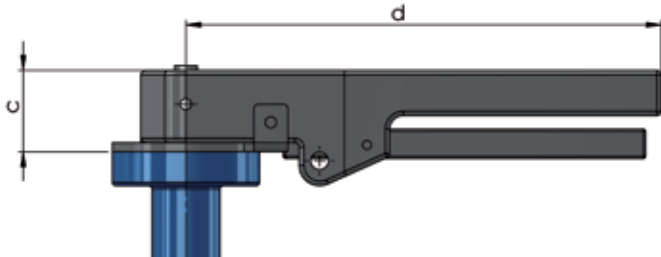

Size Inch	a	b	c	d	Weight lb
2/2½/3	1.3	1.8	1.5	8.3	3.1
4/5	1.8	2.2	1.5	11.8	4.5
6/8	3.2	3.2	1.7	19.7	5.6

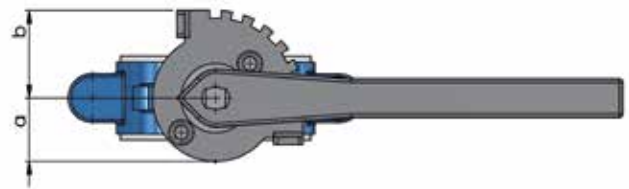

ADR-Hand-Lever

LUG + WAFER, MOBILE-SEAL

ADR Locking handle for hazardous transports

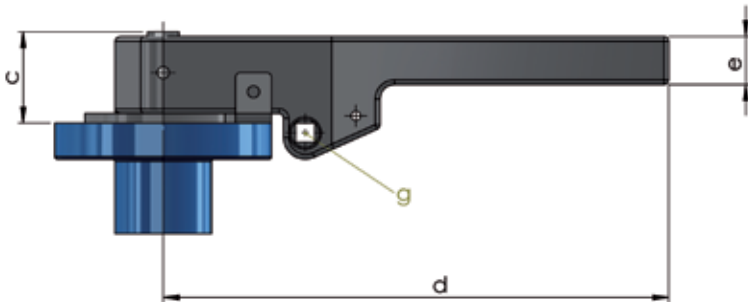

Size Inch	a	b	c	d	e	f	g	Weight lb
2, 2½, 3	1.3	1.8	1.5	8.3	0.8	0.8	0.3	1.9
4, 5	1.8	2.2	1.5	11.8	0.8	0.8	0.3	2.7
6, 8	3.2	3.2	1.7	19.7	1.0	1.0	0.3	6.8

Gear Operator

LUG + WAFER, GAR-SEAL, SAFETY-SEAL, MOBILE-SEAL, STERILE-SEAL

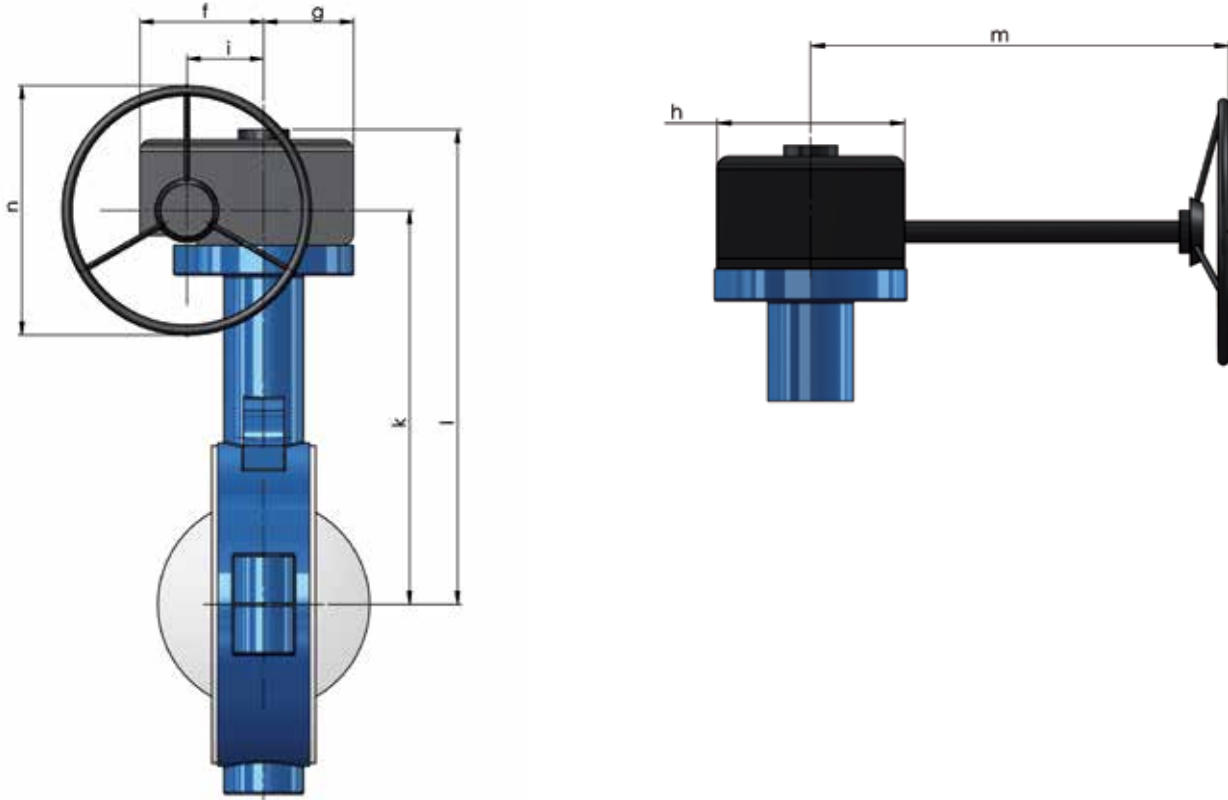

Size Inch	f	g	h	i	k*	l*	k**	l**	m	n	Gross weight (lb)	
											TYP W Wafer	TYP L Lug
2	2.4	1.8	3.5	1.5	6.6	7.8	7.1	8.3	5.9	4.9	14.6	16.3
2½	2.4	1.8	3.5	1.5	6.6	8.2	7.1	8.7	5.9	4.9	16.8	18.3
3	2.4	1.8	3.5	1.5	7.5	8.8	8.0	9.1	5.9	4.9	17.6	23.2
4	2.4	1.8	3.5	1.5	8.1	9.4	8.7	10.0	5.9	4.9	22.3	31.3
5	2.4	1.8	3.5	1.5	8.7	9.9	9.3	10.6	5.9	4.9	27.8	36.6
6	3.3	2.3	4.6	2.0	9.8	11.1	10.4	11.7	7.2	9.8	39.7	50.5
8	3.3	2.3	4.6	2.0	11.0	12.3	11.6	12.9	7.2	9.8	51.2	64.4
10	4.1	2.9	5.9	2.6	12.7	14.2	13.3	14.8	8.5	11.8	84.2	105.6
12	4.1	2.9	5.9	2.6	14.3	15.8	14.8	16.4	8.5	11.8	103.9	140.0
14	5.2	3.4	7.8	3.5	16.7	18.4	17.9	19.6	11.1	17.8	196.3	264.6
16	5.2	3.4	7.8	3.5	18.5	20.2	19.7	21.4	11.1	17.8	235.3	328.9
18	7.0	4.5	9.9	4.8	20.1	22.3	-	-	13.2	17.8	336.0	398.9
20	7.0	4.5	9.9	4.8	22.0	6.3	-	-	13.2	17.8	406.4	605.9
24	8.2	4.6	12.4	6.1	24.6	27.6	-	-	14.2	17.8	637.7	943.1

* GAR-SEAL, SAFETY-SEAL, MOBILE-SEAL

** STERILE-SEAL

Technical Data

GAR-SEAL, SAFETY-SEAL, MOBILE-SEAL, STERILE-SEAL

TORQUES

For selecting the correct valve actuation the values below represent the maximum torques for the opening and closing action.

FLOW RATE

For liquids the following references apply:
 Constant control: 14.76 f/s
 Open/Close control: 24.6 f/s

For GAR-SEAL Butterfly Valves with UHMWPE*¹-Lining the maximum flow rate is limited to 11.48 f/s.

	PTFE	PTFE antistatic PTFE abrasive	PTFE Standard vacuum* ²	PTFE antistatic / PTFE abrasive Standard vacuum * ²	UHMWPE	PTFE Special vacuum * ³
Inch	Ft. lbs					
2	25.8	25.8	25.8	25.8	30.9	not available
2½	33.2	33.2	33.2	33.2	39.8	
3	35.4	35.4	35.4	35.4	42.8	
4	50.9	59.0	61.2	67.9	61.2	
5	67.9	78.2	81.9	90.7	81.9	
6	101.8	117.3	122.4	135.7	122.4	
8	140.1	162.3	169.6	191.8	168.2	206.5
10	236.0	272.9	287.7	317.2	283.2	346.7
12	331.9	383.6	398.9	442.5	398.3	479.4
14	508.9	590.1	663.8	767.1	612.2	811.3
16	767.1	885.1	1003.1	1150.6	921.9	1216.9
18	1025.2	1180.1	1334.9	1541.5	1231.7	1622.6
20	1194.9	1379.2	1556.3	1792.3	1434.6	1880.8
24	2551.9	2942.9	3319.0	4196.7	3060.8	4056.6

*1 Ultrahighmolecular polyethylene

*2 Standard Vacuum:
 5 mm Vacuum lining up to 12"
 7 mm Vacuum lining from 14" to 24"

*3 Special Vacuum:
 7 mm 8"-12"
 10 mm 14"-24"

All stated values reflect "net" torques.
 For the actuator design a safety factor of 10 - 15 % should be taken into consideration.

P X T-DIAGRAM GAR-SEAL BUTTERFLY VALVE

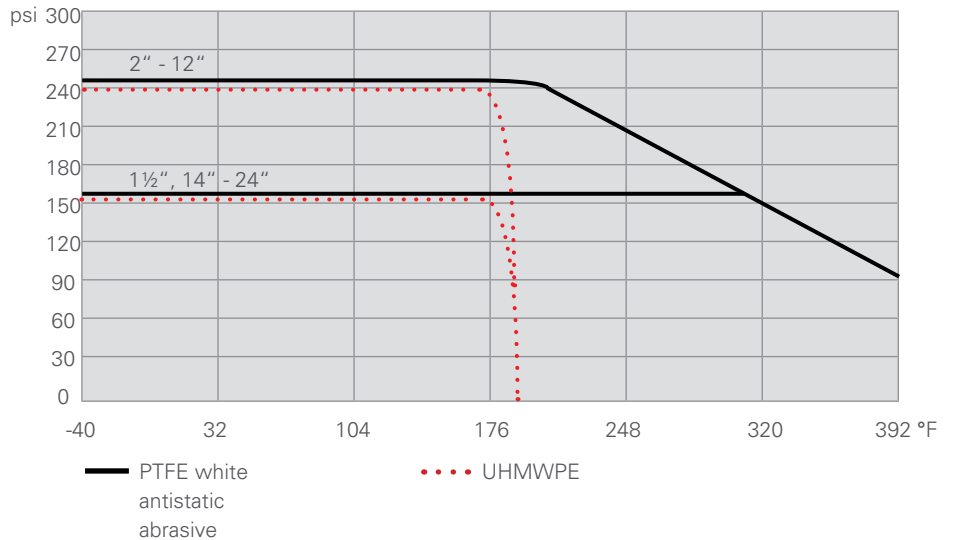

Technical Data

GAR-SEAL, SAFETY-SEAL, MOBILE-SEAL, STERILE-SEAL

OPEN/CLOSE CONTROL - CHARACTERISTIC CURVE

The graph shows the percentage flow rate, depending upon the disc-aperture. The curve reflects a throttle valve of any size with slight modifications depending upon thickness and profile of the disc itself. Throttle valves with apertures above 60° should be used for on/off control only.

ANGLE OF APERTURE

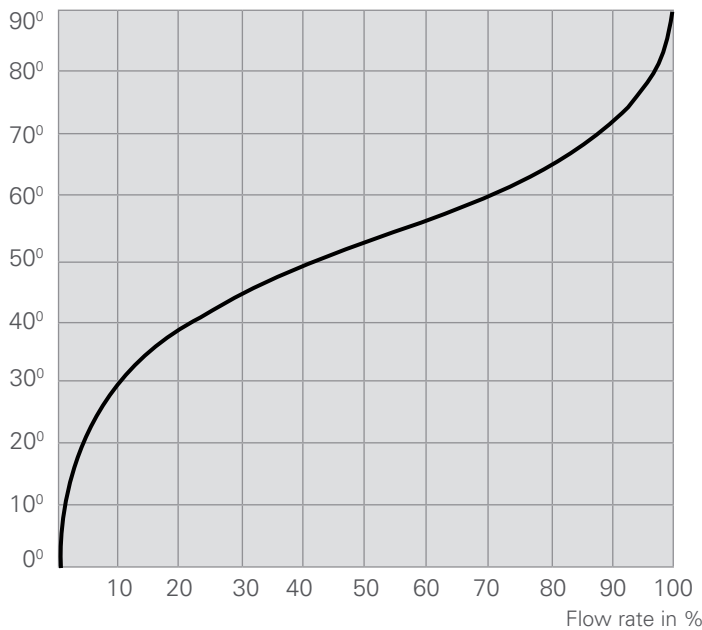

CONTINUOUS CONTROL/CHARACTERISTIC CURVE

For continuous control of a throttle valve the flow rate for a 60° aperture is defined with 100 % to provide a flow reserve. The graph has a characteristic of similar percentage for disc opening from 0° to 60°.

ANGLE OF APERTURE

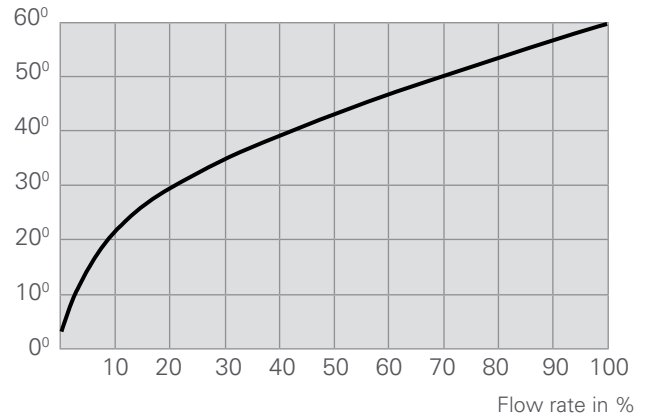

Nominal bore Inch	cv-factor against the angle of aperture							
	20%	30%	40%	50%	60%	70%	80%	90%
2	1	15	29	43	63	80	94	97
2½	2	19	39	60	95	130	151	153
3	2	19	44	93	154	222	282	283
4	10	50	101	167	265	367	463	487
5	19	71	142	244	304	577	777	824
6	26	131	249	422	635	954	1128	997
8	41	191	385	644	1014	1409	1779	1871
10	75	349	705	1177	1855	2576	3254	3422
12	111	517	1044	1745	2748	3818	4822	5070
14	158	733	1481	2474	3898	5416	6839	7192
16	225	1042	2130	3511	5533	7686	9708	10208
18	275	1273	2569	4290	6756	9390	11859	12470
20	345	1597	3226	5387	8488	11793	14893	15660
24	487	2260	4565	7621	12008	16683	21070	22156

CV-VALUES AGAINST THE ANGLE OF APERTURE

The cv-factor reflects the flow of water (density 1=1000 kg/m³) in gpm for a pressure gradient of p= 1 psi. The resistance characteristic of the butterfly valve is subject to the cv-factor. It replaces all earlier definitions, see cross-section, flow and friction coefficient. A detailed butterfly valve dimensioning for maximum flow and/or for throttle use is performed by CONVAL-Software programming. Please consult Garlock directly.

Special Vacuum Design

GARLOCK VALVES WITH SPECIAL VACUUM RESISTANT LINERS

GARLOCK VALVES HAVE FOR DECADES OPERATED UNDER EXTREME VACUUM CONDITIONS

Past statements on vacuum stress have been made and documented, but only at ambient temperature and the valve closed. This is very ambiguous to a plant engineer. Their requirements are the actual vacuum data at all temperatures. Plant vacuum can go down to 1 mbar together with higher temperatures. This often leads to leakages and malfunctions as the liner can be deformed. Garlock has developed special vacuum versions of its GAR-SEAL valves to meet these particular demands.

Vacuum applications of fluorocarbon lined valves with separate liners are subject to special parameters. Therefore not only the actual vacuum is important, but also the service temperature, the thickness of the liner and its geometry.

Garlock with its successful development program and substantial testing of various sizes, including 20", at temperatures up to 392°F concluded that such extreme service conditions can be handled.

GAR-SEAL Valves can be supplied with varying liner thicknesses for vacuum duties.

The 4" size liners show the difference between the standard 3 mm thick and the vacuum 5 mm thick liners. The liner thickness substantially improves the performance against high vacuum stress.

In the 4" valve the 3 mm thick liner will operate to 1 mbar, while the 5 mm liner operates below 1 mbar vacuum. Depending on the operating vacuum and temperature and size of valve, the liner thickness can be calculated and selected between 3 mm and 10 mm for GAR-SEAL valves.

Please contact Garlock directly for your specific requirements on vacuum applications.

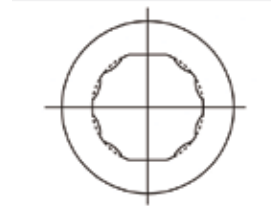

Typical appearance of high vacuum-loaded Body Liner

TEST PROCEDURE TO DETERMINE VACUUM SUITABILITY

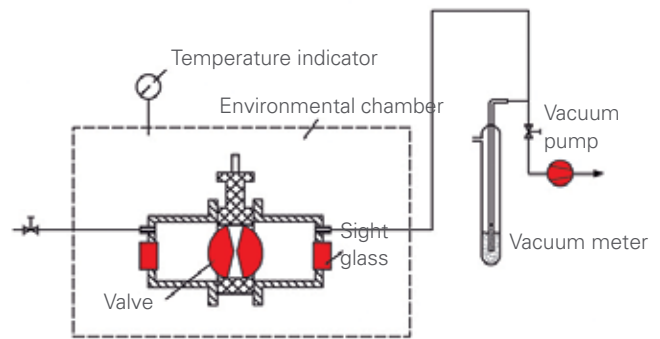

Temperature range: -24°F to 392°F
Temperature increments: Δt : 6.4°F

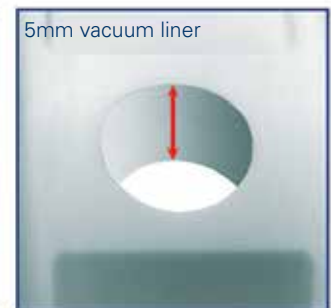

Data and Facts for Vacuum Design

FUNCTIONALLY SAFE AND LEAK FREE

FACTS AND FIGURES FOR THE USE WITH VACUUM

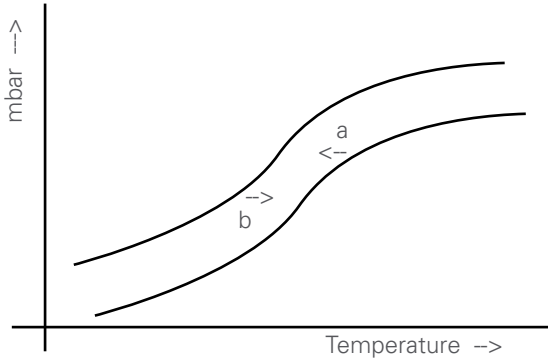

Typical characteristics of body liners under vacuum stress depending on temperature

- a) Increase size and/or decrease liner thickness
 $\frac{1}{2}'' > \frac{3}{4}''$; $s_1 < s_2$
- b) Increasing liner thickness and/or higher moment of resistance by altering geometry
 $s_2 > s_1$

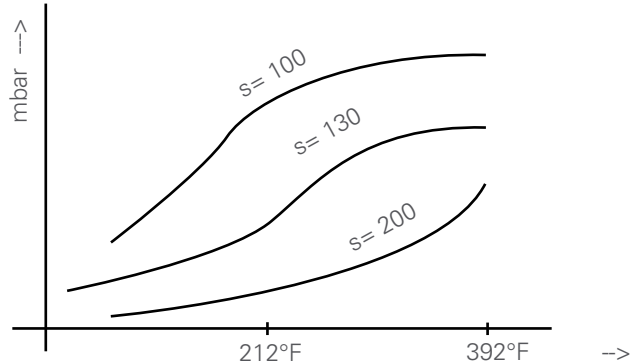

Stress example of Garlock DN 300 body liner with same geometry but different liner thickness "s"

A 30 % increase of the liner thickness at a service temperature of 320°F improves the vacuum resistance by 35 %. A doubling of the lining thickness will lead to a 85 % increase in the vacuum resistance.

RECOMMENDED APPLICATION LIMITS FOR GAR-SEAL VALVES WITH STANDARD BODY LINERS

For applications in vacuum and/or temperatures above these values special body liners are necessary. Please contact Garlock directly.



2" ≤ 6"	≤212°F	5 mbar
	> 212°F ≤ 302°F	170 mbar
	> 212°F ≤ 302°F	300 mbar
8" ≤ 12"	≤212°F	500 mbar
	> 212°F ≤ 302°F	560 mabr
	> 212°F ≤ 302°F	630 mbar
14" ≤ 24"	≤212°F	665 mbar
	> 212°F ≤ 302°F	722 mbar
	> 212°F ≤ 302°F	770 mbar

All information and recommendations contained in this catalogue are based on many years of experience and the current state of technology. Unknown factors may, however, limit generally accepted knowledge. Binding statements regarding the compatibility of our products are there -fore possible only after practical onsite tests under operating conditions. Information contained in our catalogue does therefore not constitute or imply any representation of warrantee. While the utmost care has been used in compiling this catalogue, we assume no responsibility for errors. Specifications subject to change without notice. This edition cancels all previous issues. Subject to change without notice.

Garlock

an EnPro Industries family of companies



BV1:1_01.2017

GARLOCK
an *EnPro* Industries family of companies
Tel: 1-877-GARLOCK / 315.597.4811
Fax: 800.543.0598 / 315.597.3216
www.garlock.com

Garlock
GPT
Garlock Australia
Garlock de Canada, LTD

Garlock China
Garlock Singapore
Garlock Germany
Garlock India Private Limited

Garlock de Mexico, S.A. De C.V.
Garlock New Zealand
Garlock Great Britain Limited
Garlock Middle East