

FDA Family of Dynamic Sealing Products



Leaders in Sealing Integrity



INDUSTRY CHALLENGES

Food and beverage processing industries have demanding sealing environments for rotating equipment that are amplified by daily wash down procedures and the need to maintain the highest levels of process purity to ensure product quality and safety.

WASH DOWN IMPACT

Inadequate sealing, particularly during daily wash down procedures, increases the chance of equipment and bearing failure leading to an increase in required maintenance.

↑ EQUIPMENT FAILURE **↑ MAINTENANCE REQUIRED**

WE'VE FOUND THAT

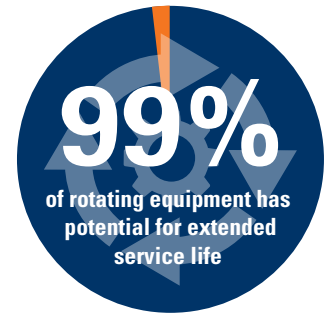
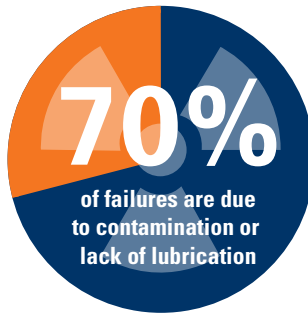
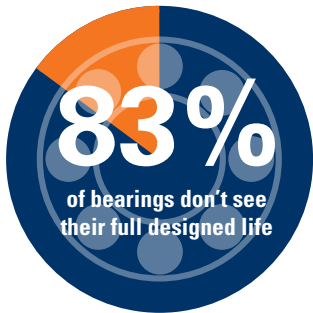

PROTECTING YOUR ROTATING EQUIPMENT

GARLOCK KLOZURE® FDA PORTFOLIO

By properly sealing motors, gearboxes and pumps, food and beverage manufacturers can dramatically extend the life of their bearings and rotating equipment. The KLOZURE® FDA portfolio of dynamic seals from Garlock provides a full suite of sealing solutions that result in cost savings, reduced maintenance, and a safer process.



PRIMARY APPLICATIONS

MOTORS



GEARBOXES



PUMPS



KLOZURE® BEARING ISOLATORS

DESIGN FEATURES

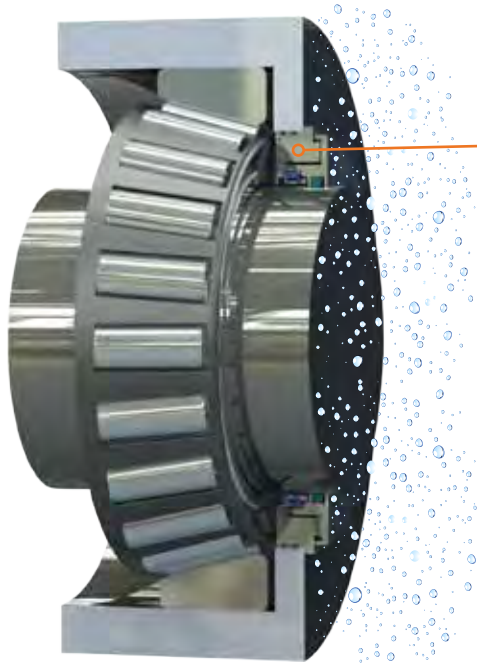

GARLOCK KLOZURE® BEARING ISOLATORS PROVIDE:

- » Ultimate bearing protection during the wash down process to extend the life of rotating equipment
- » Nearly 10x the seal life materially lengthens MTTR
- » Substantially reduced installation time - NO ARBOR PRESS NEEDED
- » Zero lubrication required
- » Non-contacting seal eliminates wearing components, reduces shaft drag, and drives energy savings, when compared to traditional lip seals

INTRODUCING KLOZURE® PUR-GARD™

UNITIZING RING

The patented unitizing ring manufactured with metal detectable and x-ray inspectable TUF-STEEL® material is a machined component with tight tolerance to maintain a labyrinth; eliminating internal metal to metal contact that generates metal shavings that could damage the bearing.

STATOR AND ROTOR

316 stainless steel construction.

OUTBOARD CONTAMINATION DRAIN

Contamination ingress will be captured in the labyrinth and expelled through the outboard drain groove (located at 6 o'clock position).

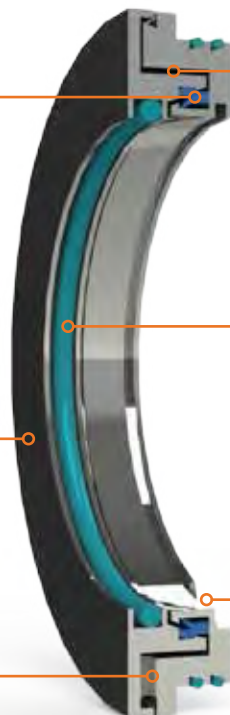

LABYRINTH PATH

Non-contacting IP66 labyrinth sealing design provides ultimate bearing protection, keeping outside contaminants from damaging the bearing.

DETECTOMER® FKM O-RING

Patented DETECTOMER® FDA compliant FKM o-rings are metal detectable/x-ray inspectable and manufactured with the optimum level of compression needed to install by hand while providing the level of bore retention demanded by harsh processes.

INBOARD LUBRICATION DRAIN

Lubrication egress will be captured by the inboard groove and redirected back into the bearing housing (located at 6 o'clock position).

PUR-GARD™

Garlock KLOZURE® Bearing Isolator

PUR-GARD™ bearing isolators offer the ultimate rotating equipment sealing solutions for the food processing industry. Manufactured with materials that are FDA compliant, metal detectable and x-ray inspectable while utilizing a patented IP66 design, PUR-GARD™ is a revolutionary seal that combines improved safety and overall process purity with cost savings through extended equipment and bearing life.

BENEFITS

- » Patented labyrinth design provides bearing protection even in the most challenging environments, extending the life of rotating equipment
- » Unitized construction will not come apart during installation
- » IP66 in most common design configurations
- » Non-contacting design reduces shaft drag and energy consumption
- » Available in a broad range of configurations
- » Substantially reduced installation time - NO ARBOR PRESS NEEDED
- » No metal-to-metal contact
- » Metal detectable and x-ray inspectable

TYPICAL APPLICATION

- » Rotating equipment (pumps, motors, gearboxes) exposed to heavy wash down and/or zone 1 and 2 applications

DESIGN PARAMETERS

- » Temperature: -22°F (-30°C) to 400°F (204°C)
- » Shaft to bore misalignment: ±0.020" (0.51 mm)
- » Axial motion to ±0.015" (0.38mm)
- » Surface speed: to 12,000 FPM Max. (60.9 m/s)
- » Pressure: Ambient
- » Non-contact labyrinth seal design

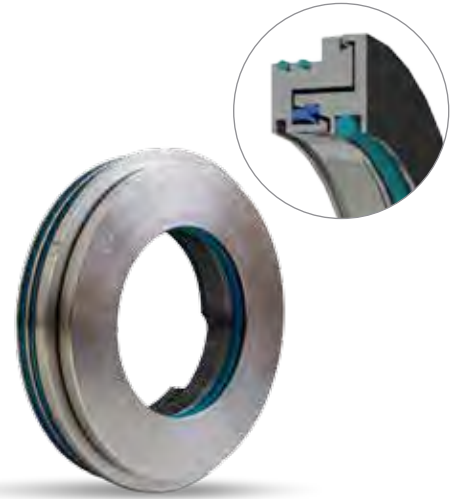

PATENTED CAM-LOCK O-RING GROOVE DESIGN

The patented Cam-Lock design of PUR-GARD™ provides excellent bore retention while allowing easy installation by hand, without the need for an arbor press.

MATERIAL OF CONSTRUCTION

- » 316 stainless steel rotor and stator
- » Patented DETECTOMER® FKM O-rings

GARLOCK PATENTED UNITIZING RING

PUR-GARD™ bearing isolators employ a patented unitizing ring to eliminate metal-to-metal contact between the rotor and stator.

BEARING ISOLATOR CONFIGURATIONS

Offered in various configurations for a perfect fit to your equipment

	PUR-GARD™
Flanged	IP66
Small Cross Section	IP66
Flangeless Narrow Width	IP55
Flangeless	IP55
Split Pillow Block	IP66
Step Shaft	IP66
Vertical	IP66
Split Option	IP66

DETECTOMER® Patents 7,390,580 & 9,701,827

ISO-GARD®

Garlock KLOZURE® Non-Metallic Bearing Isolator

KLOZURE® ISO-GARD® bearing isolators offer exceptional bearing protection for pumps, motors, and bearing supported equipment under the harshest conditions. The ISO-GARD® non-contacting design and PTFE material of construction significantly extend bearing life in rotating equipment.

BENEFITS

- » Extended bearing life drives cost savings on total cost of rotating equipment
- » Filled PTFE construction provides excellent chemical compatibility
- » Unitized construction will not come apart during installation
- » Meets IEEE 841 Test Standards
- » IP55 rated
- » Non-contacting design reduces shaft drag and energy consumption
- » Available in a broad range of configurations
- » Substantially reduced installation time - NO ARBOR PRESS NEEDED
- » Tortuous labyrinth path keeps contaminants out of the housing

TYPICAL APPLICATION

- » Rotating equipment (pumps, motors, gearboxes) with harsh chemicals or washdown and/or zone 2 and 3 applications

DESIGN PARAMETERS

- » Temperature: -22°F (-30°C) to 400°F (204°C)
- » Shaft to bore misalignment: ±0.020" (0.51 mm)
- » Axial motion to ±0.015" (0.38mm)
- » Surface speed to 4,500 f/m (22.9 m/s)
- » Pressure: Ambient
- » Non-contact labyrinth seal design



PATENTED CAM-LOCK O-RING GROOVE DESIGN

The patented Cam-Lock design of ISO-GARD® provides excellent bore retention while allowing easy installation by hand, without the need for an arbor press.

MATERIAL OF CONSTRUCTION

- » The rotor and the stator are both manufactured with FDA compliant filled PTFE
- » FDA Fluoroelastomer O-rings

BEARING ISOLATOR CONFIGURATIONS

Offered in various configurations for a perfect fit to your equipment

	ISO-GARD™
Flanged	IP55
Small Cross Section	IP55
Flangeless Narrow Width	IP55
Flangeless	IP55
Split Pillow Block	IP55
Step Shaft	IP55
Vertical	IP55
Grease Purgeable	NA
Split Option	IP55

P/S®-II

Garlock KLOZURE® Mechanical Seals

P/S®-II Mechanical Seals offers the ultimate sealing solution for viscous fluids and is trusted by leading pump OEM's and end users in the most challenging sealing environments.

BENEFITS

- » GYLON® sealing elements are non-clogging/non-sticking in viscous fluids and offer excellent chemical resistance and dry running capability
- » Unique multi-lip cartridge design is unaffected by axial end play, intermittent operation, or torque, and permits pump reversal
- » Machined gland is very versatile; designed to fit the equipment
- » Hard coated sleeve prevents damage to equipment
- » Rebuild kit available for easy in-field repair
- » One moving part—no springs to clog

TYPICAL APPLICATION

- » Positive displacement pumps made by Viking, Moyno, Blackmer, Roper, Tuthill, and many others
- » Centrifugal pumps made by Durco, Goulds, and many others
- » Conveyers
- » Rotary Valves

DESIGN PARAMETERS

- » Pressure: to 150 psi (10 bar)
- » Vacuum: 28" (711mm) Hg with proper design
- » Temperature: to 300°F (148.8°C); over 300°F, consult KLOZURE® Mechanical Seals
- » Surface speed: to 700 fpm (3.5 m/s) dry; to 2,500 fpm (12.7 m/s) with lubrication
- » Runout: up to 0.005" (0.13mm) TIR
- » Axial motion: ±0.125" (3.2mm)



MATERIALS OF CONSTRUCTION

- » Metal parts: 316SS (other materials available)
- » Set screws: Hastelloy C*
- » O-rings: Fluoroelastomer standard (other materials optional)
- » Sealing elements: GYLON®
- » Sleeve coating: Chrome oxide standard (other coatings optional)

*Hastelloy C is a registered trademark of Haynes International.

Other FDA materials available. Consult a Garlock KLOZURE® Specialist.

3D Mixer Seal

Garlock KLOZURE® Mechanical Seals

Mixer applications create some of the most challenging sealing environments in the food and beverage industries, including radial and axial movement, pressure, and vacuum during the production cycle. The KLOZURE® 3-D mixer seal provides the ultimate solution that can handle up to 1.000" of radial and axial movement, withstand pressure of up to 150 psi and 28" of vacuum.

BENEFITS

- » Compensates for extreme shaft movement
- » Dry running capabilities
- » Custom designed to fit equipment
- » Can handle up to 1.000 in / 25.4 mm of TIR, compression, and elongation

TYPICAL APPLICATION

- » Mixers for food and beverage industries

DESIGN PARAMETERS

- » Pressure: 28" Hg (711 mm Hg) to 150 psi (10 bar)
- » Vacuum: Full vacuum with proper lip configuration
- » Temperature: to 300°F (148.8°C)
- » Surface speed: to 2,500 fpm (12.7 m/s)
- » Sleeve finish: 4 to 6µ in.
- » Sleeve hardness: 50 to 70 Rockwell C
- » Sleeve coating: Specified based on application
- » Movement:
 - › 1" total indicated runout (TIR)
 - › 1" total axial movement (TAM)

(specific movements calculated per application)

*above 150psi consult KLOZURE®



MATERIALS OF CONSTRUCTION

- » Sleeve and seal housing: 316SS, 20SS, Hastelloy, titanium
- » Flexible housing: PTFE, 316 SS, Hastelloy C 276

*Hastelloy C is a registered trademark of Haynes International.

Other FDA materials available. Consult a Garlock KLOZURE® Specialist.

PS-SEAL

GYLON® Powered High Performance Seal

The PS-SEAL provides reliable, dynamic sealing at high circumferential speed, high pressure, and extreme temperature environments. This seal is also capable of sealing abrasive and aggressive media.

PS-SEAL is used in many different applications such as food, beverage & pharmaceutical applications, and can also be an alternative to mechanical seals and braided packing.

The high performance PS-SEAL is manufactured with Garlock's industry leading GYLON® lip material.

BENEFITS

- » Superior performance under high pressure and extreme vacuum
- » Suitable for high circumferential shaft speeds
- » Temperature resistant from -130°F (-90°C) up to 500°F (260°C)
- » Excellent chemical resistance
- » FDA compliant
- » EN 1935/2004 certificate
- » SIP/CIP compatible
- » Excellent dry running capability
- » Wear resistant and low friction characteristics



STANDARD CONFIGURATION

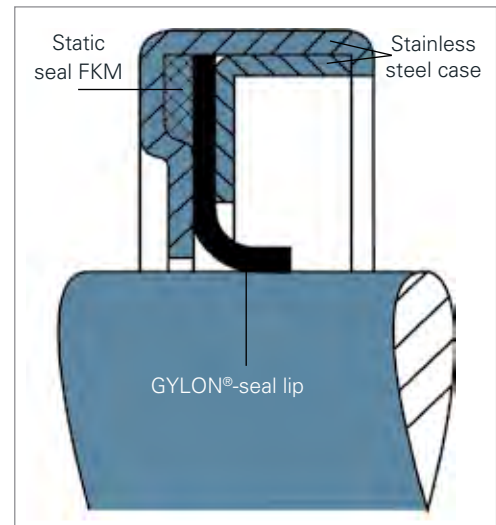

REVERSE LIP

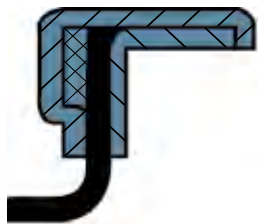

SIMPLE LIP WITH DUST LIP

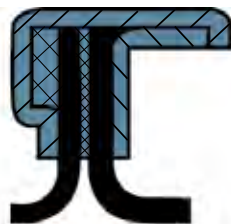

DUAL OPPOSED

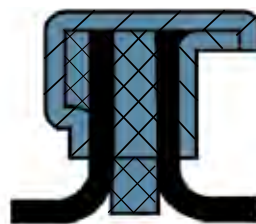

DUAL TANDEM

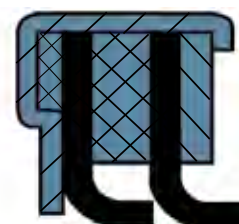

The overview shows the most common configurations. Other configurations are also available upon request.

Model 23 Oil Seal

Garlock KLOZURE® Oil Seal

Garlock KLOZURE® Model 23 split oils seal in FDA approved silicone provides longevity and easy installation for your general service oil seal requirements. Available in over 300,000 sizes and with 24 hour turn around available, the Model 23 allows for quick and easy installation for immediate oil seal needs.

BENEFITS

- » General service split seal that requires no disassembly of surrounding equipment
- » Molded-in stainless steel finger spring, prevents spring dumping (also available without spring)

TYPICAL APPLICATION

- » Rotating equipment with requirement for FDA compliance



DESIGN PARAMETERS

- » Temperature: -75°F to 350°F
- » Misalignment: 0.010" @ 1000fpm
- » Surface speed: 2000fpm (10.2m/s)
- » Pressure: Ambient
- » Cover plate required

MATERIAL OF CONSTRUCTION

- » FDA silicone

Model 25 Oil Seal

Garlock KLOZURE® Oil Seal

Garlock KLOZURE® Model 25 split PTFE seals are designed to provide sealing capabilities for environments that necessitate excellent chemical resistance or low speed service.

BENEFITS

- » Special low speed service PTFE seal
- » Excellent chemical resistance
- » Offered in split or solid

TYPICAL APPLICATION

- » Rotating equipment with exposure to chemical washdown



DESIGN PARAMETERS

- » Temperature: -120°F to 400°F
- » Misalignment: 0.010" @ 500fpm
- » Surface speed: 1000fpm (10.2m/s)
- » Pressure: Ambient
- » Cover plate required
- » Stainless steel garter spring (also available without spring)

MATERIALS OF CONSTRUCTION

- » Virgin PTFE

BEARING ISOLATORS

PUR-GARD™

PUR-GARD™ stainless steel bearing isolators offer the ultimate rotating equipment solution, combining improved safety and process purity with cost savings through extended equipment life.



KEY FEATURES:

- » Metal detectable and x-ray inspectable
- » IP66 protection
- » Patented cam-lock o-ring design and unitizing ring

ISO-GARD®

ISO-GARD® bearing isolators offer exceptional bearing protection for pumps, motors, and bearing supported equipment under the harshest conditions, including harsh chemicals and heavy wash down.



KEY FEATURES:

- » Filled PTFE construction provides excellent chemical compatibility
- » Unitized construction will not come apart during installation
- » Meets IEEE 841 Test Standards
- » IP55 protection

OIL SEALS

MODEL 23

Model 23 provides an excellent quick turnaround FDA silicone split sealing option combined with KLOZURE® world-class oil seal technology.



KEY FEATURES:

- » General service split seal
- » Over 300,000 sizes readily available
- » Molded in stainless steel finger spring, prevents spring dumping

MODEL 25

Model 25 provides a split seal option with PTFE material. Ideal for low speed service applications.



KEY FEATURES:

- » PTFE split seal
- » Excellent chemical resistance

PS-SEAL®

PS-SEAL® stands for reliable sealing of rotating shafts at high circumferential speed, high pressure, and extreme temperatures. Seals aggressive and abrasive media.



KEY FEATURES:

- » Manufactured with Garlock's industry leading GYLON® lip material
- » Usable under high pressure and extreme vacuum
- » EN 1935/2004 certificate
- » SIP/CIP compatible
- » Good dry running capability
- » Wear resistant and low friction

MECHANICAL SEALS

P/S®-II

P/S®-II seals offer the ultimate sealing solutions for viscous fluids and is trusted by leading pump OEM's and end users in the most challenging sealing environments.



KEY FEATURES:

- » GYLON® sealing elements
- » Unique multi-lip cartridge design
- » One moving part, no springs to clog
- » Dry running capabilities

3D MIXER SEAL

3-D mixer seals can handle up to 1.000" of radial and axial movement, run in dry conditions, and withstand pressure of up to 150 psi, and 28" of vacuum.



KEY FEATURES:

- » Compensates for extreme shaft movement
- » Dry running capabilities
- » Custom designed to fit equipment

APPLICATION DATA SHEET

Customer Information

Contact: _____
Company: _____

Phone: _____
Email: _____

Current Seal Information (If Available)

Seal Manufacturer: _____
 Seal Part Number: _____
 Seal Type: _____
 Seal Element Material: _____
 Seal Case Material: _____

Approximate Cost: _____
 Approximate Usage: _____

Application Information

General

Equipment Type: _____
Shaft Orientation: Vertical Horizontal
Function of Seal: Retain Exclude Both

Size/Finish

(A) Shaft Diameter: _____ in mm
 Shaft Surface Finish: _____ in mm
 Shaft Surface Hardness: _____ in mm
(B) Bore Diameter: _____ in mm
 Bore Surface Finish: _____ in mm
 Bore Surface Hardness: _____ in mm
(C) Bore Depth: _____ in mm
 (D) Shaft Chamfer: _____ in mm
 (E) Bore Chamfer: _____ in mm
(F) Distance to Obstruct: _____ (Needed for Bearing Isolators)

Motion

Shaft Motion: Rotating Reciprocating Stationary
Housing Motion: Rotating Reciprocating Stationary
Shaft Speed (rotation): _____ RPM fpm mps
 Housing Speed (rotation): _____ RPM fpm mps

Alignment/Movement

Radial Misalignment: _____ inch mm
 Shaft Runout: _____ inch mm
 Axial Movement: _____ inch mm

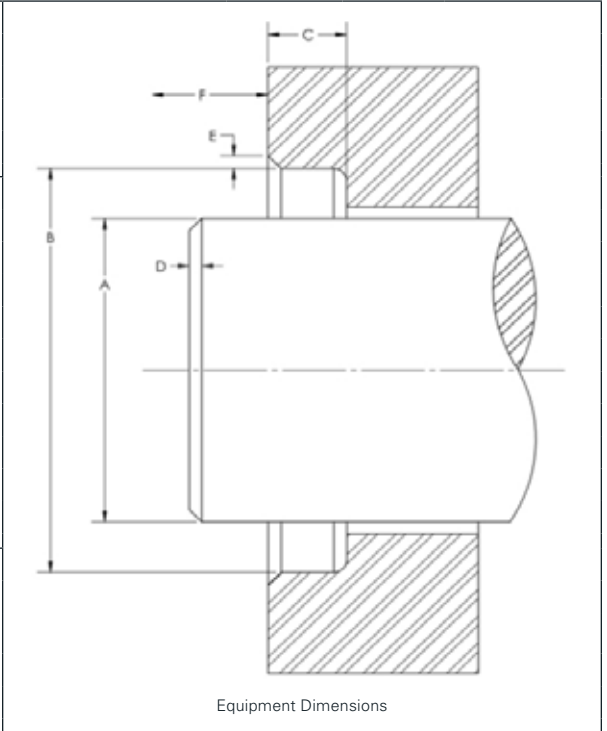

Pressure

Location: Internal External
Pressure Value: _____
 psi bar kp

Media

Internal Media Type: Grease Oil Oil Mist
Internal Media Level: Dry Partial Submerged

External Media Type: Dirt/Dust Water Cleaning agent
 Rolling Solution None
External Media Level: Dry Partial Submerged
 Airborne Contaminates Splashes

Temperature

Nominal: _____ °F °C
 Minimum: _____ °F °C
 Maximum: _____ °F °C

Notes

Bold Fields are Required

Garlock Family of Companies
1666 Division Street
Palmyra, New York 14522 USA

1-866-556-9873 | 1-315-597-3216
Fax: 1-800-543-0598 | 1-315-597-3039

www.garlock.com

© 2018 Garlock Family of Companies. All rights reserved. Garlock is
an EnPro Industries, Inc. family of companies (NYSE: NPO).

KLZ 2-115 06.2018

Garlock
an EnPro Industries family of companies

